

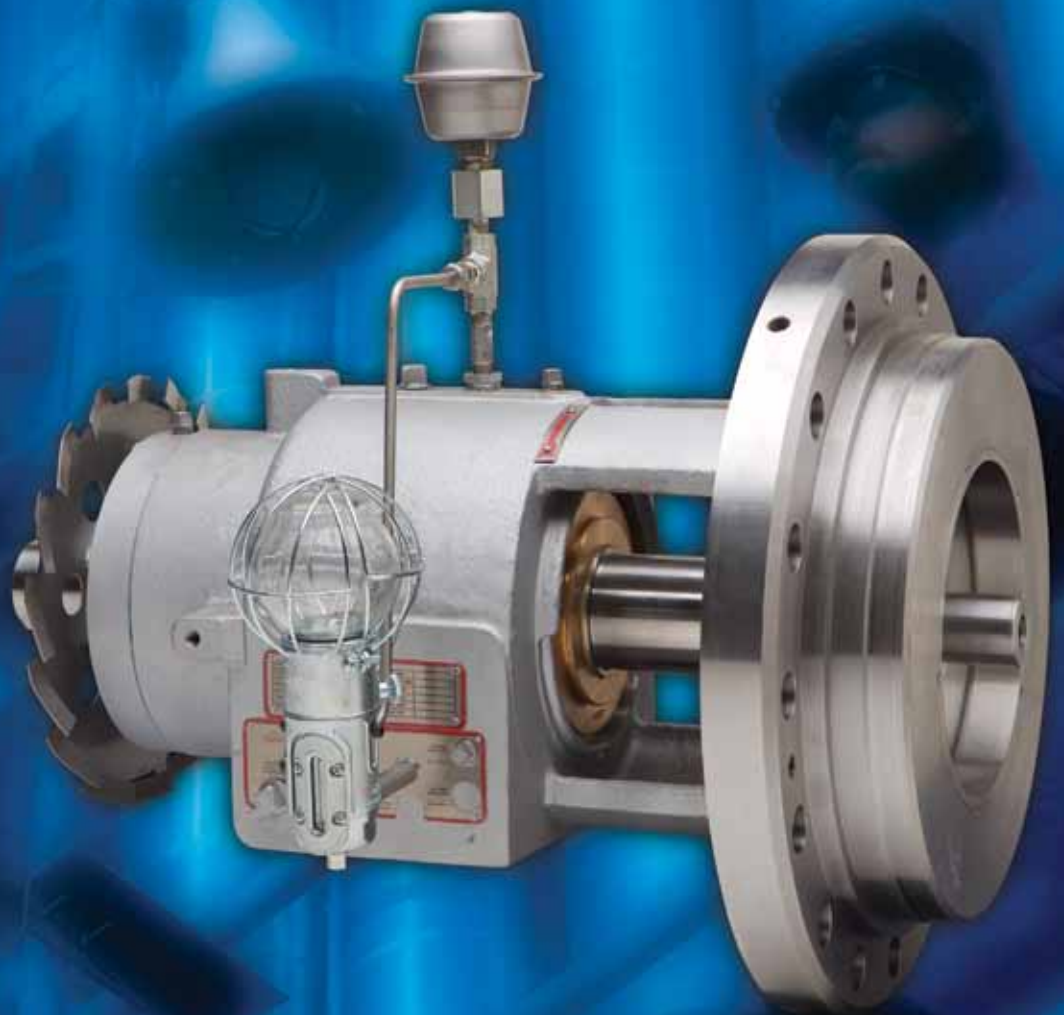

***RVX Upgrade  
ISO 13709/API 610 Back Pull-out Retrofit***

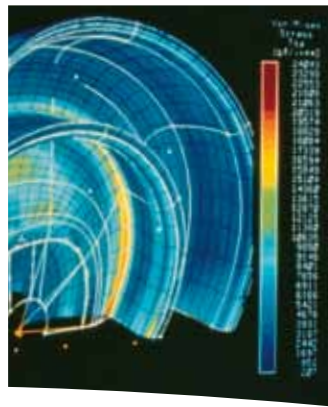

***Experience In Motion***



## ***Pump Supplier to the World***

*Flowserve is the driving force in the global industrial pump marketplace. No other pump company in the world has the depth or breadth of expertise in the successful application of pre-engineered, engineered, and special purpose pumps and systems.*

### ***Life Cycle Cost Solutions***

Flowserve provides pumping solutions that permit customers to reduce total life cycle costs and improve productivity, profitability and pumping system reliability.

### ***Market-Focused Customer Support***

Product and industry specialists develop effective proposals and solutions directed toward market and customer preferences. They offer technical advice and assistance throughout each stage of the product life cycle, beginning with the initial inquiry.

### ***Broad Product Lines***

Flowserve offers a wide range of complementary pump types, from pre-engineered process pumps to highly engineered and special purpose pumps and systems. Pumps are built to recognized global standards and customer specifications.

Pump designs include:

- Single-stage process
- Between bearings single-stage
- Between bearings multistage
- Vertical
- Submersible motor
- Positive displacement
- Nuclear
- Specialty

### ***Product Brands of Distinction***

*ACEC™ Centrifugal Pumps*

*Aldrich™ Pumps*

*Byron Jackson® Pumps*

*Calder™ Energy Recovery Devices*

*Cameron™ Pumps*

*Durco® Process Pumps*

*Flowserve® Pumps*

*IDP® Pumps*

*Lawrence Pumps®*

*Niigata Worthington™ Pumps*

*Pacific® Pumps*

*Pleuger® Pumps*

*Scienco™ Pumps*

*Sier-Bath® Rotary Pumps*

*TKL™ Pumps*

*United Centrifugal® Pumps*

*Western Land Roller™ Irrigation Pumps*

*Wilson-Snyder® Pumps*

*Worthington® Pumps*

*Worthington Simpson™ Pumps*

**RVX Upgrade  
ISO 13709/API 610  
Back Pull-out Retrofit**



**The Upgrade Specialists**

*FlowsERVE developed the RVX back pull-out assembly upgrade program to address users' needs for improved pump reliability with reduced maintenance costs. The RVX program assists users in reducing fugitive volatile organic compound (VOC) emissions while gaining the advantages of a bearing frame in full compliance with ISO 13709/API 610, latest edition. It also addresses users' needs for improving pump hydraulic efficiency or operating stability by replacing existing impellers with ones specifically selected for current operating modes. This dedicated aftermarket support program makes FlowsERVE unbeatable as a problem solver for improving field equipment reliability and reducing total life cycle costs.*

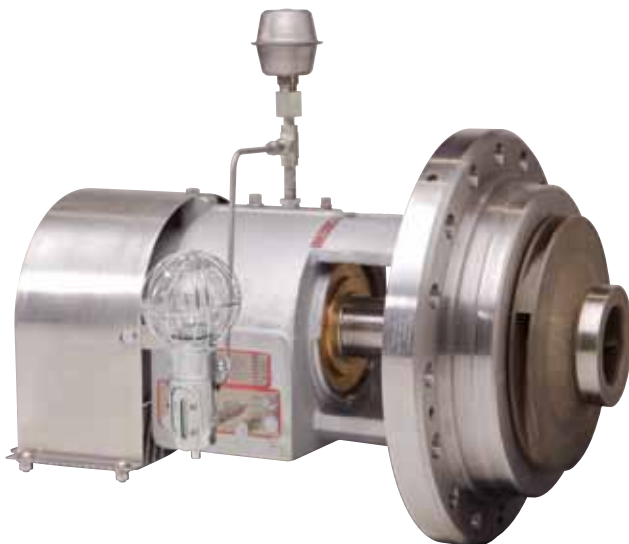

**RVX Upgrade Benefits**

The RVX program applies to any existing ISO/API OH1 and OH2 pump installation, regardless of OEM.

- Increased reliability based upon a robust design with larger radial and thrust bearings and low  $L^3/D^4$  ratio
- Full compliance with API 610  $L_{10h}$  bearing life requirements
- Increased seal life attributed to large diameter shaft with low  $L^3/D^4$  ratio for reduced shaft deflection with increased mean time between repair (MTBR) and reliability
- Elimination of cooling water by an outboard fan for heat convection
- No disturbance to existing suction and discharge piping
- High parts interchangeability based upon same parts used from new FlowsERVE HPX pump product
  - Three standard frame sizes accommodate impeller diameters from 215 mm (8.5 in) to 525 mm (21 in)
  - Utilizes standard OEM cartridge seals
- Pristine, closed lubrication system with bearing isolators for increased mean time between repair (MTBR)
- Oil slinger design to mitigate "dirty oil" appearance
- Quick Ship Program for significantly reduced turnaround time to upgrade existing pumps versus replacing with new equipment. Upgrade in two to five weeks versus new pumps in 38 weeks

**RVX Upgrade**  
**ISO 13709/API 610**  
**Back Pull-out Retrofit**

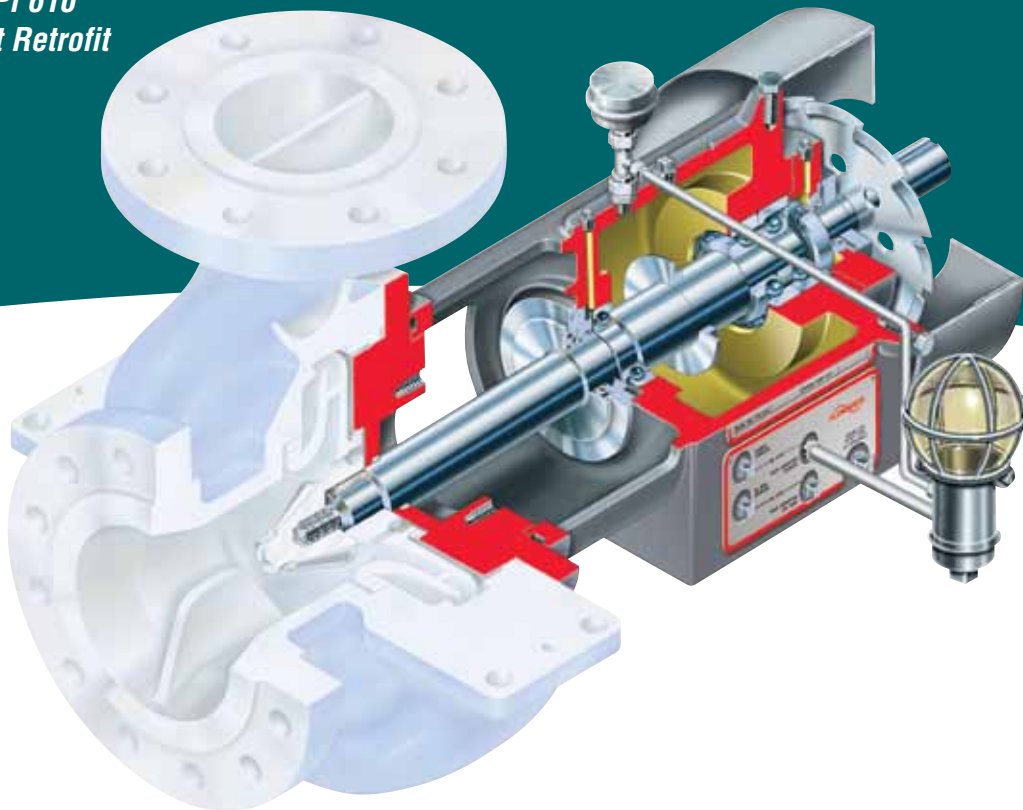

*The RVX assembly enables users to extend the useful life of process pumps while simultaneously reducing the total cost of ownership. It accomplishes this by upgrading low technology or obsolete bearing assemblies and seal chambers to ISO 13709/API 610, latest edition compliant components. Standard RVX assemblies include the following new components:*

- Bearing housing and shaft assembly
- Head, fixed throat bushing and integral seal chamber
- Head wear ring
- Cooling fan
- Guard for fan
- Keys for impeller and coupling

The application of current technology combined with dedicated support by aftermarket specialists ensures improved MTBR of any ISO/API OH2 single-stage, two-stage or double-suction overhung pump.

**Features and Benefits**

**Heavy-duty Construction to ISO 13709/API 610**, latest edition, including carbon steel bearing housing assures maximum reliability and safety.

**Metal-to-Metal Casing/Cover** fit with fully confined, controlled compression gasket ensures proper sealing and alignment.

**Outboard Cooling Fan** reduces shaft temperature migration on high-temperature services.

**Large Radial and Thrust Bearings**, combined with very low shaft stiffness ratios ( $L^3/D^4$ ) and low shaft deflection, promote long life for bearings and mechanical seals.

**Pristine Closed Lubrication System** with expansion chamber, oiler and Inpro® bearing isolators ensures optimal bearing lubrication and prevents ingress of contaminants and moisture for increased MTBR. Oil slinger design mitigates "dirty oil" appearance. Oil mist optional.

**Fixed Throat Bushing Design** accommodates metallic and non-metallic bushings, permitting greater control of seal chamber pressure to suit application needs.

**ISO 21049/API 682 Seal Chamber** accommodates all popular dual seal arrangements without special engineering.

**Air Gap** between drip pocket and cover helps insulate the bearing housing in high-temperature applications.

© Inpro is a trademark of Inpro/Seal Company.

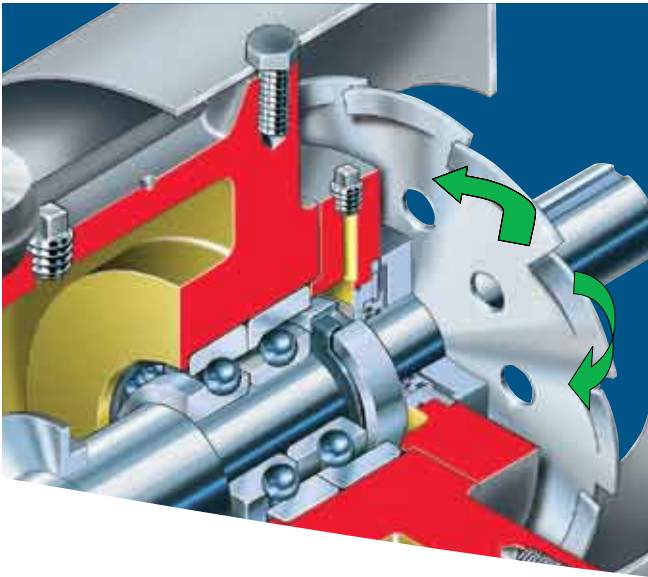

*RVX assembly with expansion chamber, standard oiler, fan guard and optional coupling guard*



**Standard Outboard Fan**

Standard outboard fan eliminates the need for bearing cooling water and extends the operating temperature of the pump to 450°C (840°F) with no auxiliary support required.

**Maximized Parts Interchangeability**

The RVX enables users to maximize parts interchangeability. All ISO/API OH1 and OH2 single-stage, two-stage and double-suction overhung pump wet ends, regardless of OEM, may be retrofitted with the RVX. Bearing housing parts are interchangeable with HPX and HPXM components.

**Dimensional Consistency**

With very few exceptions, the pump’s discharge centerline to driver coupling face dimension remains unchanged on pumps retrofitted with the RVX. This is accomplished by selecting a longer coupling spacer, if necessary, to permit a drop-in-place assembly. Additionally, shafts are machined to fit the original pump dimensions.

**Significantly Reduced Lead Time**

The RVX retrofit improves pump performance and reliability significantly faster than purchasing a new pump. Typical lead time for a new pump is 38 weeks; the typical lead time for an RVX is just five weeks — a savings of 33 weeks.

**Quick Payback and Reduced Life Cycle Costs**

**Reliability Payback**

The reliability payback of the RVX in a recent 50-pump program was 1.84 years as calculated by the user. This was based on the significant reduction in cost and time to upgrade the pull-out assemblies versus completely replacing pumps. Improved reliability to ISO 13709/API 610, latest edition, is also assured.

**Energy Payback**

Energy payback on the RVX can be realized by application of an optimized impeller. Consider the following facts from an actual case history:

- Reduction of 100 kW/h (135 hp/h)
- Power cost reduction of US\$35 415 annually using US\$0.04 per kW/h and around-the-clock operation
- 0.62 years payback on energy savings

**New Product Warranty**

Flowserve offers a new product warranty on all RVX assemblies.

**Lead Time Comparison**

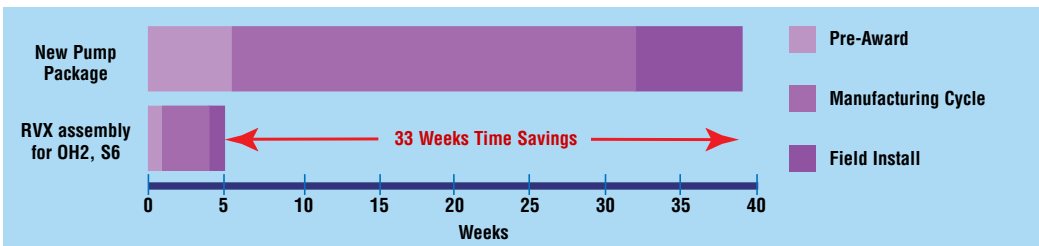

**Hydraulic  
Rerates,  
Options and  
Technical Data**

*RVX assembly with rerated impeller and new mechanical seal*

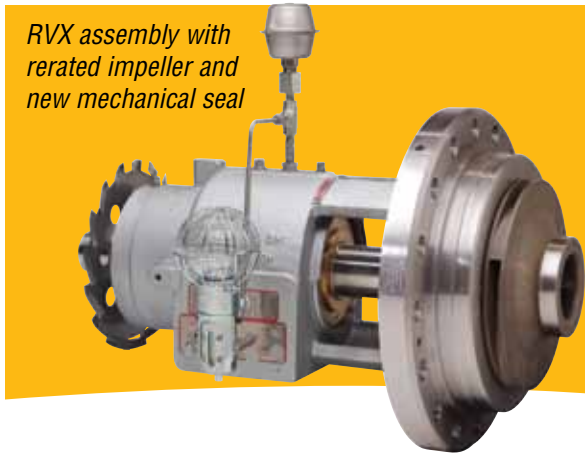

**Hydraulic Rerates for  
Optimal Performance**

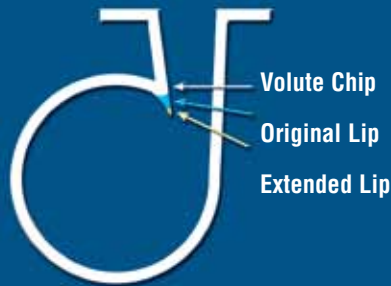

**Customized Volute to Impeller Relationship**

The relationship between the casing volute and the impeller can be customized to improve hydraulic stability over the entire pump operating range.

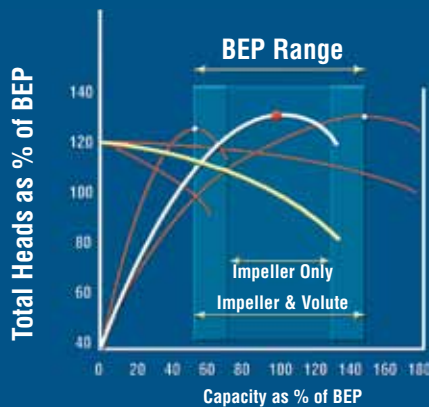

**New or Rerated Impeller**

A new or rerated impeller can be provided as an option to meet changing operating conditions.

**Electronic Documentation**

The RVX upgrades include the following electronic documentation:

- Cross sectional drawing
- Outline drawing of pump
- Seal chamber drawing
- IOM manual addendum
- Parts list

The following electronic documents are provided when applicable:

- Coupling drawing
- Seal assembly drawing
- Seal flush schematic
- Required baseplate modification instructions

**Optional Hardware Package**

- Impeller
- Mechanical seal
- Seal flush piping
- Coupling and coupling guard

**Material Upgrades**

Material upgrades can be incorporated into upgrade kits for improved operating life of these parts:

- Cover
- Shaft
- Gaskets
- Wearing rings (metallic or non-metallic)
- Throat bushing (metallic or non-metallic)

**Service and Repair Options**

- Casing repair
- Pump assembly
- Field inspection
- Field engineering
- Field machining

**Global Service  
and Technical  
Support**



## Life Cycle Cost Solutions

Typically, 90% of the total life cycle cost (LCC) of a pumping system is accumulated after the equipment is purchased and installed. Flowserve has developed a comprehensive suite of solutions aimed at providing customers with unprecedented value and cost savings throughout the life span of the pumping system. These solutions account for every facet of life cycle cost, including:

**Capital Expenses**

- Initial purchase
- Installation

**Operating Expenses**

- Energy consumption
- Maintenance
- Production losses
- Environmental
- Inventory
- Operating
- Removal

### Innovative Life Cycle Cost Solutions

- New Pump Selection
- Turnkey Engineering and Field Service
- Energy Management
- Pump Availability
- Proactive Maintenance
- Inventory Management

### Typical Pump Life Cycle Costs<sup>1</sup>

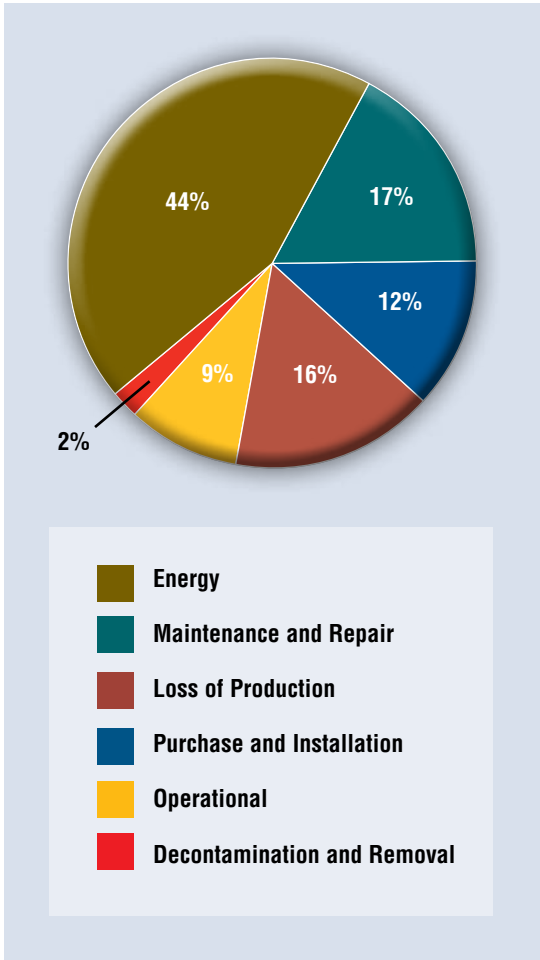

<sup>1</sup> While exact values may differ, these percentages are consistent with those published by leading pump manufacturers and end users, as well as industry associations and government agencies worldwide.

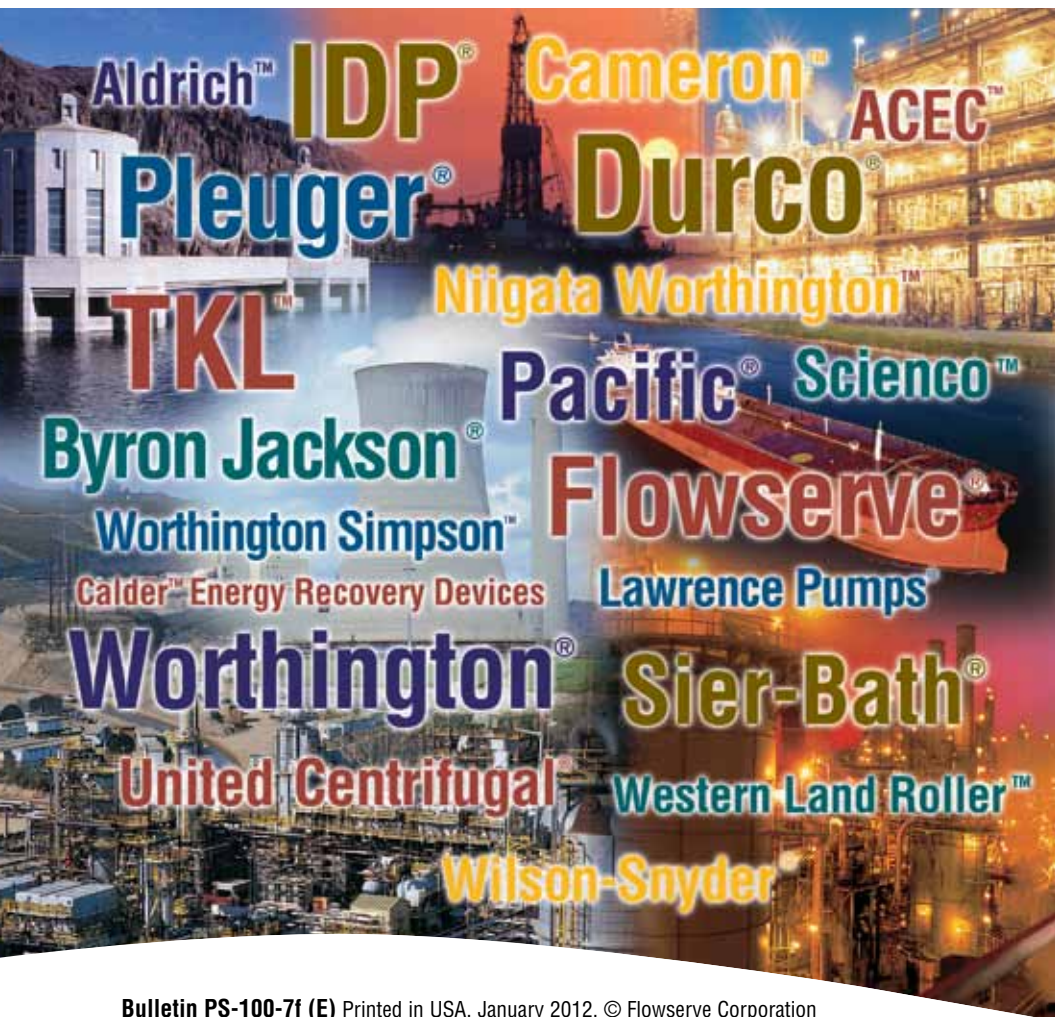

**USA and Canada**

Flowserve Corporation  
5215 North O'Connor Blvd.  
Suite 2300  
Irving, Texas 75039-5421 USA  
Telephone: +1 937 890 5839

**Europe, Middle East, Africa**

Flowserve Corporation  
Parallelweg 13  
4878 AH Etten-Leur  
The Netherlands  
Telephone: +31 76 502 8100

**Latin America**

Flowserve Corporation  
Martín Rodríguez 4460  
B1644CGN-Victoria-San Fernando  
Buenos Aires, Argentina  
Telephone: +54 11 4006 8700  
Telefax: +54 11 4714 1610

**Asia Pacific**

Flowserve Pte. Ltd.  
10 Tuas Loop  
Singapore 637345  
Telephone: +65 6771 0600  
Telefax: +65 6862 2329

Bulletin PS-100-7f (E) Printed in USA. January 2012. © Flowserve Corporation

**To find your local Flowserve representative:**

For more information about Flowserve Corporation,  
visit [www.flowserve.com](http://www.flowserve.com) or call +1 937 890 5839.