

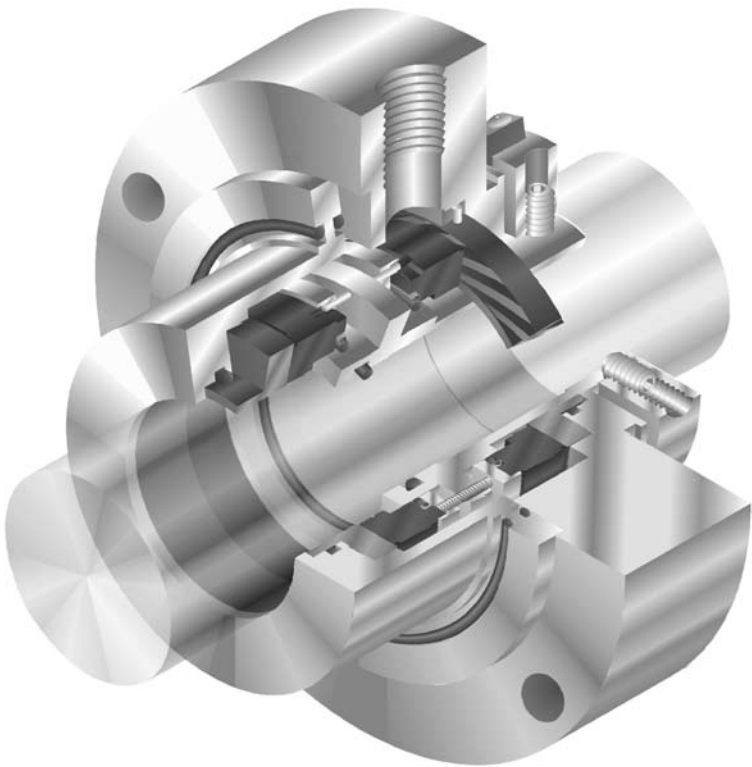

Installation Instructions

Dual Gas Barrier Seals

GB-200, GF-200, GX-200,
and BufferPac



1 Equipment Check

- 1.1 **Follow plant safety regulations** prior to equipment disassembly:
 - Lock out motor and valves.
 - Wear designated personal safety equipment.
 - Relieve any pressure in the system.
 - Consult plant MSDS files for hazardous material regulations.
- 1.2 **Disassemble equipment** in accordance with equipment manufacturer's instructions to allow access to seal installation area.
- 1.3 **Remove existing mechanical seal and gland** or compression packing and packing gland (follower flange).
- 1.4 **Check seal chamber** to ensure that it is the appropriate design for the seal you are installing. Dual gas seal configurations are designed for both standard bore and enlarged bore seal chambers.

Seal Chamber Requirements

Figure 1

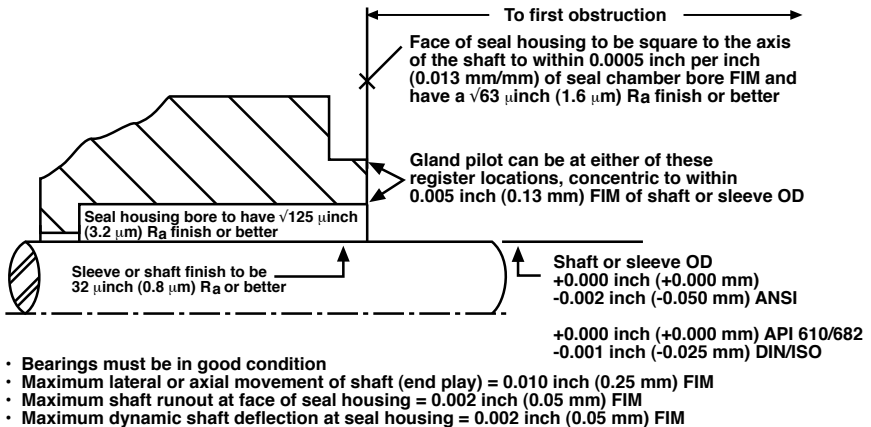

- 1.5 Make sure the **shaft or sleeve and the seal chamber face are clean** and free of burrs, cuts, dents, or corrosion that might cause leakage past the sleeve packing or housing O-ring gasket. Replace worn shaft or sleeve. **Remove sharp edges** from keyways and threads.

- 1.6 **Check equipment dimensions.** They must agree with the dimensions shown in Figure 1 and the assembly drawing supplied with the seal. Critical dimensions include shaft or sleeve OD and the minimum distance to the first obstruction.
- 1.7 **Check gland bolting** to ensure that bolt diameter and bolt circle conform to the dimensions shown in the assembly drawing.
- 1.8 **Check seal chamber stud length** to ensure that they conform to the dimensions shown in the assembly drawing. Assembly may require longer studs or use of bolts or cap screws if existing studs are not long enough.
- 1.9 Check rotation direction of the equipment. Uni-directional seal designs must be operated only in the direction shown on the seal gland.
- 1.10 Handle the **seal with care**, it is manufactured to precise tolerances. The sealing faces of the rotors and stators are specially finished. **Keep the seal faces perfectly clean at all times.** Oil, silicone lubrication, or type of grease should **not** be applied to these seal faces.

2 Dual Gas Barrier Seal Installation

Tools needed:

Provided

- **Krytox*** lubricant for sleeve O-rings

Not provided

- **Open end wrench** for gland nuts
- **Allen wrenches** for setting devices and set screws
- **Allen wrenches** for gland cap screws if they are required in place of gland nuts or bolts

Install Seal Cartridge

Figure 2

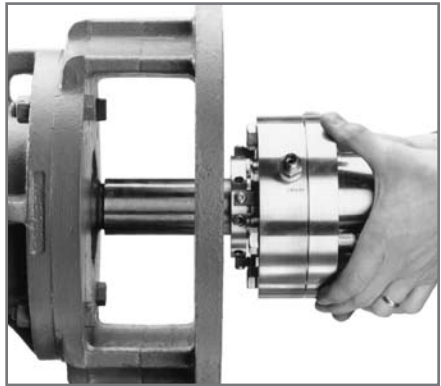

- 2.1 **Lubricate the shaft or sleeve OD** lightly with Krytox lubricant provided. If bolts or cap screws are required in place of the seal chamber studs, insert them through the gland bolt holes before sliding the assembly onto the shaft. **Slide the complete seal cartridge onto the shaft**, Figure 2, with the end with the setting devices toward the bearing housing.

Note: Check for rotation direction requirements on the seal gland or assembly drawing before continuing.

*Krytox a Registered Trademark of E.I.DuPont

2.1.1 **Optional:** TARSEx Bushing Installation

- Slide seal assembly against the bearing frame.
- Clean lubrication off pump shaft.
- Install the friction drive TARSEx bushing with O-ring, positioning them against the retaining plate with the bushing grooves oriented toward the seal. See Figure 3.

Install TARSEx Bushing (optional) Figure 3

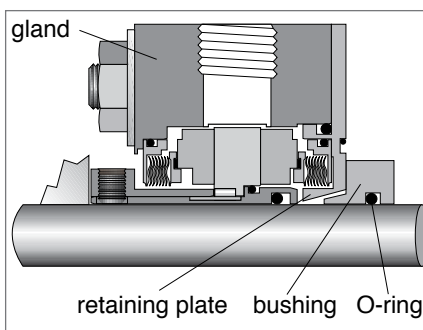

- 2.2 **Install the pump seal chamber, Figure 4. Position the seal gland** gas barrier inlet, port **A** shown in Figure 5, in the 9:00 o'clock position and the plugged gas barrier outlet, port **B** in the 6:00 o'clock position for normal installations. Alternate positioning of the gland may be necessary with some pumps, where the bearing housing interferes with piping. **Bolt the seal chamber in place** on the bearing housing.

Install pump seal chamber Figure 4

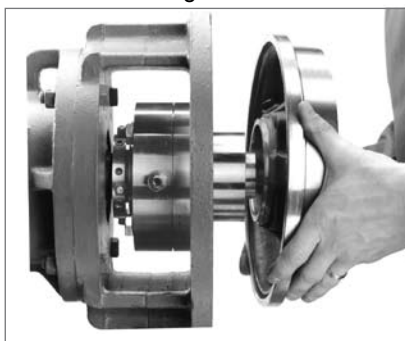

Note: Either port can be used for gas barrier inlet or outlet.

- 2.3 **Assemble the pump, adjust the bearings, set the impeller, connect pump piping.** Allow no pipe strain on the pump casing. **Connect the coupling** so that the shaft is in its operating axial position.

Position gland inlet

Figure 5

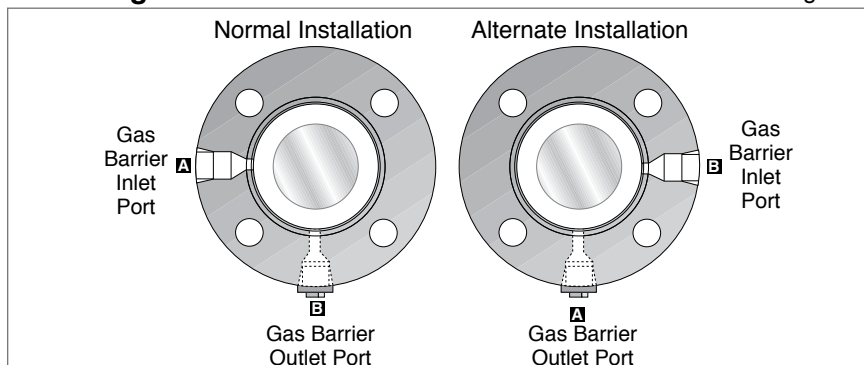

- 2.4 **Position the seal** with housing O-ring gasket in place against the seal chamber face and **tighten the gland nuts** evenly in a diagonal sequence. Do not over tighten the gland nuts.
- 2.5 **Using a cross-tightening method tighten the set screws** on the seal cartridge drive collar, Figure 6.

Tighten drive collar set screws

Figure 6



Remove setting devices

Figure 7

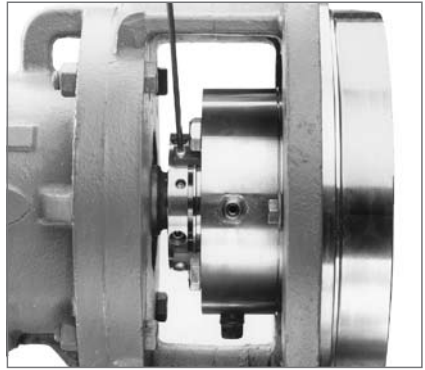

- 2.6 **Remove setting devices** by removing the screws with an Allen wrench, Figure 7. Save the setting devices and screws for future use in either removing the seal from service or to reset the pump impeller, see section 5.
- 2.7 **Turn the shaft by hand to ensure free operation.**
- 2.8 **Pipe up the gland connections** to the seal, see section 3.
- 2.9 **See Operational Recommendations, section 4, before starting pump.**

3 Piping

The Dual Gas Barrier Seal is designed to be operated in a normally dry running mode with a pressurized clean inert gas (nitrogen) or air between the two seals.

The gland is equipped with a gas barrier inlet and outlet connection.

- 3.1 **Vent out the gas barrier line** prior to connecting to the seal gland to ensure that foreign material has not collected in the piping.

3.2 **Connect gas barrier Plan 74 shown in Figure 8 to the gas barrier inlet port** (refer to Figure 5). The pressure gage and regulator are required to set the barrier gas pressure 25 to 50 psig (2 to 4 bar) higher than that of the product being sealed (seal chamber pressure).

Note: It is important that the pressure gage and the low pressure alarm be installed close to the gas barrier inlet port for accurate values.

An optional control panel that incorporates all the equipment in a plan 74 for a Dual Gas Barrier Seal is available from Flowserve.

3.3 Plug the gas barrier outlet port, (refer to Figure 5), or connect to a block valve.

Plan 74 for Dual Gas Barrier Seal

Figure 8

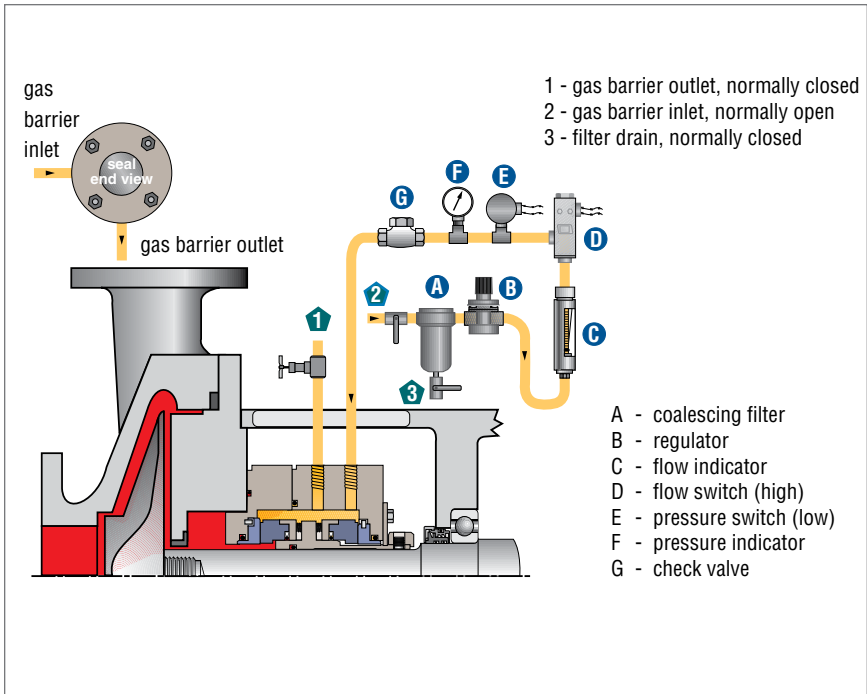

4 Operation

To assure reliable, long-life operation of your Dual Gas Barrier Seal, the following guidelines should be observed.

- 4.1 **Do not exceed corrosion limits.** Your Flowserve seal is designed to resist corrosion by most chemicals. However, do not expose the seal materials of construction to products outside of their corrosion limits. The seal assembly drawing lists the materials of construction. Consult Flowserve for chemical resistance ratings.
- 4.2 **Do not exceed the pressure limits of the seal design. Do not let the barrier gas pressure fall** below 25 psi (2 bar) above the seal chamber pressure.
- 4.3 **Do not exceed the maximum temperature** limits of the seal design.
- 4.4 **Do not operate at speeds lower** than the seal's minimum speed, if applicable.
- 4.5 **For uni-directional designs,** do not turn the shaft opposite to the direction arrow indicated on the gland.
- 4.6 **Observe the start-up.** The seal barrier cavity must be pressurized before pump start-up and at all times during pump operation. For best performance, do not cavitate or run the pump dry. Open valves to flood pump with product fluid before start-up. Maintain the seal barrier gas pressure even when the pump is not running.

5 Reset pump impeller

To reset the pump impeller, follow plant safety procedures, etc., see 1.1.

- Reinstall the setting devices.
- Loosen the cartridge drive collar set screws.
- Adjust the impeller clearance following pump manufacturer's instructions.
- Tighten the set screws on the cartridge drive collar.
- Remove the setting devices. Save the setting devices and screws.
- Perform steps 2.7 to 2.9.



TO REORDER REFER TO
B/M # _____
F.O. _____

6 Repair

This product is a precision sealing device. The design and dimension tolerances are critical to seal performance. Only parts supplied by Flowserve should be used to repair a seal. To order replacement parts, refer to the part code and B/M number. A spare backup seal should be stocked to reduce repair time.

When seals are returned to Flowserve for repair, **decontaminate the seal assembly** and include an order marked "**Repair or Replace.**" **A signed certificate of decontamination must be attached. A Material Safety Data Sheet (MSDS) must be enclosed** for any product that came in contact with the seal. The seal assembly will be inspected and, if repairable, it will be rebuilt, tested, and returned.

FIS108eng REV 11/10 Printed in USA

To find your local Flowserve representative and find out more about Flowserve Corporation, visit www.flowserve.com

Flowserve Corporation has established industry leadership in the design and manufacture of its products. When properly selected, this Flowserve product is designed to perform its intended function safely during its useful life. However, the purchaser or user of Flowserve products should be aware that Flowserve products might be used in numerous applications under a wide variety of industrial service conditions. Although Flowserve can provide general guidelines, it cannot provide specific data and warnings for all possible applications. The purchaser/user must therefore assume the ultimate responsibility for the proper sizing and selection, installation, operation, and maintenance of Flowserve products. The purchaser/user should read and understand the Installation Instructions included with the product, and train its employees and contractors in the safe use of Flowserve products in connection with the specific application.

While the information and specifications contained in this literature are believed to be accurate, they are supplied for informative purposes only and should not be considered certified or as a guarantee of satisfactory results by reliance thereon. Nothing contained herein is to be construed as a warranty or guarantee, express or implied, regarding any matter with respect to this product. Because Flowserve is continually improving and upgrading its product design, the specifications, dimensions and information contained herein are subject to change without notice. Should any question arise concerning these provisions, the purchaser/user should contact Flowserve Corporation at any one of its worldwide operations or offices.

© Copyright 2007 Flowserve Corporation

USA and Canada

Kalamazoo, Michigan USA
Telephone: 1 269 381 2650
Telefax: 1 269 382 8726

Europe, Middle East, Africa

Roosendaal, the Netherlands
Telephone: 31 165 581400
Telefax: 31 165 554590

Asia Pacific

Singapore
Telephone: 65 6544 6800
Telefax: 65 6214 0541

Latin America

Mexico City
Telephone: 52 55 5567 7170
Telefax: 52 55 5567 4224