



Installation Instructions

Single Inside Pusher Type Seals

BPO, BPT, BRO, BRT, PTO, PT, RO, RO-TT,
and others



1 Equipment Check

- 1.1 **Follow plant safety regulations** prior to equipment disassembly:
 - lock out motor and valves.
 - wear designated personal safety equipment.
 - relieve any pressure in system.
 - consult plant MSDS files for hazardous material regulations.
- 1.2 **Disassemble equipment** to allow access to seal installation area.
- 1.3 **Remove all burrs** and sharp edges from the shaft or sleeve including sharp edges of keyways and threads. Replace worn shaft or sleeve. Make sure the seal housing bore and face are clean and free of burrs.
- 1.4 **Check requirements** for shaft, sleeve and seal housing.
See Figure 1.

Seal Chamber Requirements

Figure 1

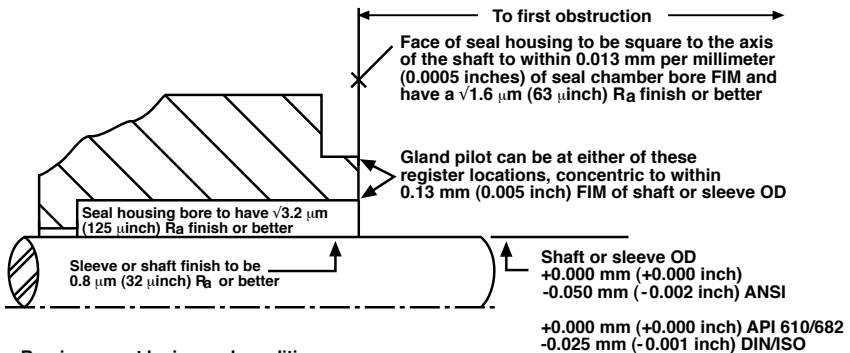

- Bearings must be in good condition
- Maximum lateral or axial movement of shaft (end play) = 0.25 mm (0.010 inch) FIM
- Maximum shaft runout at face of seal housing = 0.05 mm (0.002 inch) FIM
- Maximum dynamic shaft deflection at seal housing = 0.05 mm (0.002 inch) FIM

- 1.5 **Check assembly drawing** included with the seal for specific seal design, materials of construction, dimensions, and piping connections.
- 1.6 **Check shaft or sleeve OD, box bore, box depth, and distance to the first obstruction** to ensure that they are dimensionally the same as shown on the seal assembly drawing.
- 1.7 **Check gland pilot and bolt holes** to ensure they are adaptable to the equipment and are the same as shown on the assembly drawing.

The images of parts shown in these instructions may differ visually from the actual parts due to manufacturing processes that do not affect the part function or quality.

- 1.8 **Handle all seal parts with care**, they are manufactured to precise tolerances. The seal faces; rotating face, and stationary face, are of special importance. These two sealing faces are lapped flat to within three light bands (34.8 millionths of an inch).
Keep the seal faces perfectly clean at all times.

Single Inside Pusher Type Seal Installation

2 Single End Suction Vertical Split Case Pumps (1 box)

- 2.1 **Scribe mark A** on the shaft or sleeve to line up with the face of the seal housing.
- 2.2 **Scribe mark B** at the seal setting point shown enclosed in a rectangular box on the assembly drawing included with the seal. This seal setting dimension is measured from the face of the seal housing to the back of the spring holder. The back of the spring holder will be located at this point.
- 2.3 **Lubricate the shaft** or sleeve lightly with silicone lubricant provided with the seal before installing any seal parts.
- 2.4 **Lightly lubricate O-ring or Duraflex seat gasket.**
- 2.5 **Press the stationary face into the gland** (flexibly mounted stationary faces only). Use hand pressure only. Where a face has an O-ring mounting on the back shoulder, it is usually better to nest this O-ring into the gland cavity and then push the face into the nested O-ring.
- 2.6 **Install the gland** with stationary face over the shaft. Place the gland as close to the bearing bracket as possible. Do not bump the stationary face against the shaft as it may chip, crack, or break.
- 2.7 Install the **rotating face gasket** into the bore of the rotating face.
- 2.8 **Install the rotating face** components on the shaft or sleeve in the proper sequence. Handle PTFE U-cup rings and Durafite rotating face gaskets with extreme care. PTFE U-cup rings must be assembled individually and not pushed on the shaft or sleeve while they are installed on the rotating face. Avoid nicking or pinching either lip of the U-cup ring. Use both U-cup rings, they work together to form an effective seal.

- 2.9 Set the back of the spring holder at reference mark B, Figure 1, and tighten set screws firmly and evenly. The rotating component assembly is now in the proper position to provide the correct setting and spring compression for final assembly.
- 2.10 **Wipe the seal faces** clean with alcohol before completing equipment assembly. Seal faces should not be lubricated, but should be left clean and dry.
- 2.11 **Assemble the pump.**
- 2.12 **Position the gland** to the face of the seal housing. Be sure the gland pilot is properly engaged. **Tighten the gland stud nuts** evenly, cross stagger the adjustment of the nuts. Follow the equipment manufacturer's recommendations for gland stud nut torque. In the absence of recommendations, gland nuts should only be torqued to establish a leak tight seal at the gland gasket. Proper gland bolt adjustment is especially important with clamp style stationary faces where excessive torque may damage the face.
- 2.13 **See Operational Recommendations** before starting pump.

3 Double Suction and Multistage Horizontal Split Case Pumps (2 boxes)

- 3.1 **Scribe mark A** on the shaft or sleeve to line up with the face of the seal housing.
- 3.2 **Scribe mark B** at the seal setting point shown enclosed in a rectangular box on the assembly drawing included with the seal. This seal setting dimension is measured from the face of the seal housing to the back of the spring holder. The back of the spring holder will be located at this point.
- 3.3 **Lubricate the shaft** or sleeve lightly with silicone lubricant provided with the seal before installing any seal parts.
- 3.4 **Install the rotating face gasket** into the bore of the rotating face.
- 3.5 **Install the rotating seal components** on the shaft or sleeve in the proper sequence. Handle PTFE U-cup rings and Durafite rotating face gaskets with extreme care. PTFE U-cup rings must be assembled individually and not pushed on the shaft or sleeve while

they are installed in the rotating face. Avoid nicking or pinching either lip of the U-ring. Use both U-cup rings, they work together to form an effective seal.

- 3.6 Set the back of the spring holder at reference mark B, Figure 1, and tighten set screws firmly and evenly. The rotating component assembly is now in the proper position to provide the correct setting and spring compression for final assembly.
- 3.7 **Lightly lubricate O-ring or Duraflex stationary face gaskets.**
- 3.8 **Press the stationary face into the gland** (flexibly mounted face only). Use hand pressure only. Where a face has an O-ring mounting on the back shoulder, it is usually better to nest this O-ring into the gland cavity and then push the face into the nested O-ring.
- 3.9 **Wipe the seal faces** clean with alcohol before completing equipment assembly. Seal faces should not be lubricated, but should be left clean and dry.
- 3.10 **Position the gland** to the face of the seal housing. Be sure the gland pilot is properly engaged. **Tighten the gland stud nuts** evenly, cross stagger the adjustment of the nuts. Follow the equipment manufacturer's recommendations for gland stud nut torque. In the absence of recommendations, gland nuts should only be torqued to establish a leak tight seal at the gland gasket. Proper gland bolt adjustment is especially important with clamp style stationary faces where excessive torque may damage the face.
- 3.11 **Assemble the pump.**
- 3.12 **See Operational Recommendations** before starting pump.

4 Vertical In-line Pumps

For back pullout designs and shaft designs not incorporating a rigid spacer coupling use procedure 1, as for single end suction vertical split case pumps.

For shaft designs incorporating a rigid spacer coupling:

- 4.1 **Scribe mark A** on the shaft or sleeve to line up with the face of the seal housing. Some pump designs incorporate a shaft or sleeve with vertical or horizontal pins for setting and driving the seal. In these cases no seal setting measurements are required.

- 4.2 **Scribe mark B** at the seal setting point shown enclosed in a rectangular box on the assembly drawing included with the seal. This seal setting dimension is measured from the face of the seal housing to the back of the spring holder. The back of the seal spring holder will be located at this point.
- 4.3 **Lubricate the shaft** or sleeve lightly with silicone lubricant provided with the seal before installing any seal parts.
- 4.4 **Install the rotating seal** components into the bore of the rotating face.
- 4.5 **Install the rotating seal** component parts on the shaft or sleeve in the proper sequence. Handle PTFE U-cup rings and Durafite rotating face gaskets with extreme care. PTFE U-cup rings must be assembled individually and not pushed on the shaft or sleeve while they are installed in the rotating face. Avoid nicking or pinching either lip of the U-cup ring. Use both U-rings, they work together to form an effective seal.
- 4.6 Set the back of the spring holder at reference mark B, Figure 1, and tighten set screws firmly and evenly. In cases where the spring holder is provided with drive slots to engage with the pins there are no set screws to tighten. Install the rotating components over the shaft or sleeve and into the bore of the seal housing being sure the slots in the spring holder engage the drive pins. The rotating component assembly is now in the proper position to provide the correct setting and spring compression for final assembly.
- 4.7 **Lightly lubricate O-ring or Duraflex stationary face mountings.**
- 4.8 **Press the stationary face into the gland** (flexibly mounted faces only). Use hand pressure only. Where a face has an O-ring mounting on the back shoulder, it is usually better to nest this O-ring into the gland cavity and then push the stationary face into the nested O-ring.
- 4.9 **Wipe the seal faces** clean with alcohol before completing equipment assembly. Seal faces should not be lubricated, but should be left clean and dry.
- 4.10 **Position the gland** to the face of the seal housing. Be sure the gland pilot is properly engaged. **Tighten the gland stud nuts** evenly, cross stagger the adjustment of the nuts. Follow the equipment manufacturer's recommendations for gland stud nut

torque. In the absence of recommendations, gland nuts should only be torqued to establish a leak tight seal at the gland gasket. Proper gland bolt adjustment is especially important with clamp style stationary faces where excessive torque may damage the face.

4.11 **Assemble the pump.**

4.12 **See Operational Recommendations** before starting pump.

5 Operational Recommendations

5.1 **Do not start up the equipment dry.** Vent air from the casing of the pump and the seal chamber before startup. Circulate clean product or a clean fluid from an external source through the seal chamber whenever the equipment is in operation, API Plan 11 or 32.

5.2 If the seal runs hot, check for proper seal setting, seal housing dimensions, and check the bypass or flush line for obstructions. Do not allow the equipment to run for any extended time if the seal gets hot or squeals.

For special problems encountered during installation, contact your nearest Flowserve Sales and Service Representative or Authorized Distributor.

6 Repair

This product is a precision sealing device. The design and dimension tolerances are critical to seal performance. Only parts supplied by Flowserve should be used to repair a seal. To order replacement parts, refer to the part code and B/M number. A spare backup seal should be stocked to reduce repair time.

When seals are returned to Flowserve for repair, **decontaminate the seal assembly** and include an order marked "**Repair or Replace.**" **A signed certificate of decontamination** must be attached.

A Material Safety Data Sheet (MSDS) must be enclosed for any product that came in contact with the seal. The seal assembly will be inspected and, if repairable, it will be rebuilt, tested, and returned.



TO REORDER REFER TO
B/M # _____
F.O. _____

FIS105eng 02/12 Printed in USA

**To find your local Flowserve representative
and find out more about Flowserve Corporation, visit
www.flowserve.com**

Flowserve Corporation has established industry leadership in the design and manufacture of its products. When properly selected, this Flowserve product is designed to perform its intended function safely during its useful life. However, the purchaser or user of Flowserve products should be aware that Flowserve products might be used in numerous applications under a wide variety of industrial service conditions. Although Flowserve can provide general guidelines, it cannot provide specific data and warnings for all possible applications. The purchaser/user must therefore assume the ultimate responsibility for the proper sizing and selection, installation, operation, and maintenance of Flowserve products. The purchaser/user should read and understand the Installation Instructions included with the product, and train its employees and contractors in the safe use of Flowserve products in connection with the specific application.

While the information and specifications contained in this literature are believed to be accurate, they are supplied for informative purposes only and should not be considered certified or as a guarantee of satisfactory results by reliance thereon. Nothing contained herein is to be construed as a warranty or guarantee, express or implied, regarding any matter with respect to this product. Because Flowserve is continually improving and upgrading its product design, the specifications, dimensions and information contained herein are subject to change without notice. Should any question arise concerning these provisions, the purchaser/user should contact Flowserve Corporation at any one of its worldwide operations or offices.

© Flowserve Corporation (2012)

USA and Canada

Kalamazoo, Michigan USA
Telephone: 1 269 381 2650
Telefax: 1 269 382 8726

Europe, Middle East, Africa

Roosendaal, the Netherlands
Telephone: 31 165 581400
Telefax: 31 165 554590

Asia Pacific

Singapore
Telephone: 65 6544 6800
Telefax: 65 6214 0541

Latin America

Mexico City
Telephone: 52 55 5567 7170
Telefax: 52 55 5567 4224