

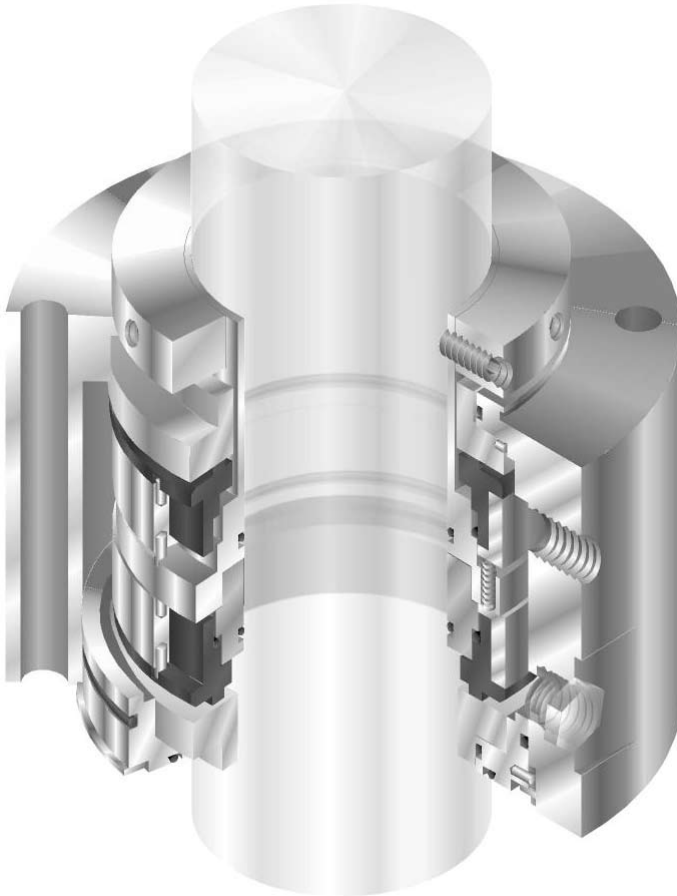

Installation Instructions

MD-200 Series

Conditioned Gas Dual Cartridge
Canister Seal for Mixers and Agitators



1 Equipment Check

- 1.1 **Follow plant safety regulations** prior to equipment disassembly:
 - **Consult** the plant Material Safety Data Sheet (MSDS) files for hazardous material regulation.
 - **Wear** designated personal safety equipment.
 - **Lock out** the mixer or agitator motor and valves to and from the vessel.
 - **Relieve** any pressure in the vessel.
 - Use plant **vessel entry procedures** if it is necessary to enter the vessel.
- 1.2 **Secure the mixer or agitator shaft** in accordance with the mixer or agitator manufacturer's instructions.
- 1.3 **Remove the coupling and/or drive** to access the seal area. Follow the manufacturer's instructions.
- 1.4 **Remove the existing seal assembly.**
- 1.5 **Remove all burrs and sharp edges** from the shaft and vessel flange area. The shaft and vessel flange must be free of burrs, sharp edges, cuts, dents, or corrosion that might cause leakage past the sleeve packing O-rings and the vessel flange O-ring gasket.
- 1.6 **Check requirements** for the shaft and the vessel flange. They must agree with the dimensions shown in Figure 1.
- 1.7 **Check the assembly drawing** accompanying the seal assembly for specific seal design data, materials of construction, dimensions, and recommended piping connections.
- 1.8 **Check the shaft OD, vessel flange bolt size, bolt circle, and distance to the coupling or drive** to ensure that these dimensions agree with the seal assembly drawing provided.
- 1.9 **Handle the seal assembly with care**, it is manufactured to precise tolerances. The sealing faces of the rotors and the stators are of special importance. These sealing faces are lapped to rigid specifications required for contacting face gas seals. If it becomes necessary to disassemble the seal, **keep these sealing faces clean and dry at all times** and **protect them from damage** since they are subject to impact fracture.

1.10 **Pressure testing** of this cartridge canister dual seal prior to installation is possible using filtered dry nitrogen or instrument air. Consult Flowserve, Flow Solutions for acceptable gas leakage rates for this seal design.

Mixer/Agitator Shaft and Flange Requirements

Figure 1

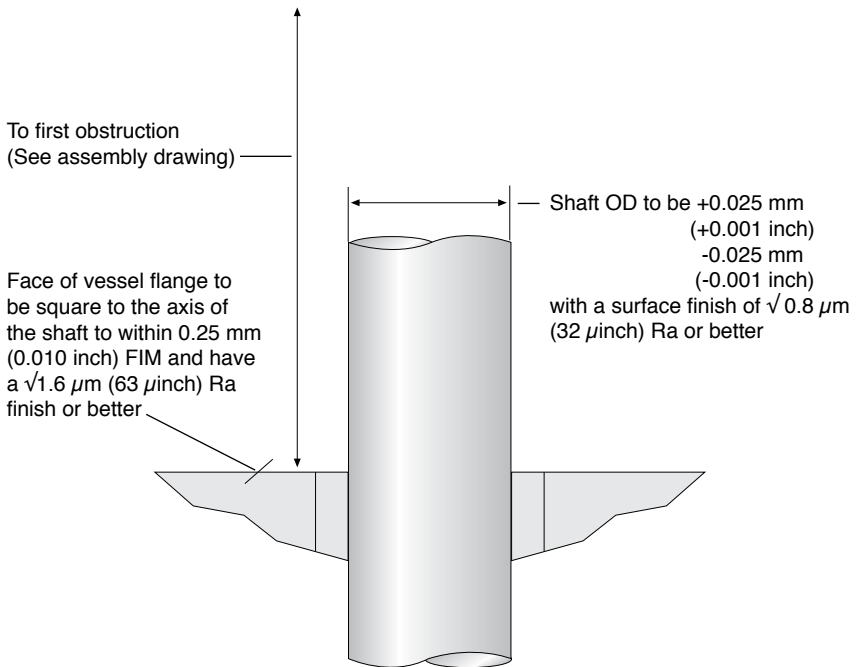

- Bearings, drive, and coupling must be in good condition
- Maximum vertical shaft movement (axial end play) = 0.61 mm (0.024 inch) FIM
- Maximum static vessel flange out of concentricity = 0.50 mm (0.020 inch) FIM
- Maximum static vessel flange to shaft out of squareness = 0.25 mm (0.010 inch) FIM
- Maximum dynamic shaft deflection = 3 mm (0.125 inch) FIM

The MD-200 Seal design may include an optional radial bearing in the canister to protect the seal from excessive shaft runout or whip.

2 MD-200 Seal Installation

Tools needed:

Tools provided:

- ***Krytox lubricant** for O-rings and equipment shaft OD.

Tools not provided:

- **Wrenches** to secure housing nuts or bolts
- **Allen wrenches** for housing cap screws
- **Allen wrenches** for seal setting devices and set screws

- 2.1 **Install the seal adapter plate** on the vessel flange if required.
- 2.2 **Lightly lubricate the equipment shaft** along the entire length the gasket O-rings will contact the shaft. Use the Krytox lubricant provided if it is compatible with the process fluid.
- 2.3 **Secure the vessel flange O-ring** in the gasket O-ring groove using the Krytox lubricant provided if it is compatible with the process fluid.
- 2.4 **Install the MD-200 Seal onto the equipment shaft** with the end containing the setting devices toward the equipment drive end and position the seal assembly onto the vessel flange. Use the lifting eyes supplied to gently lower the canister assembly onto the adapter plate. Do not bolt the canister seal assembly to the adapter plate or vessel flange at this time. Care should be exercised when passing the seal sleeve incorporating the sleeve packing O-rings over any keyways or threads that may be present. Any steps or shoulders on the equipment shaft should be beveled to prevent damage (pinching and cutting) of these sleeve packing O-rings during installation.
- 2.5 **Position the canister seal assembly** so that the barrier gas ports and any optional bearing lubrication fittings are easily accessible.
- 2.6 **Reinstall the shaft coupling and/or drive. Remove any shaft holding or restraining clamps** and complete adjustments so that the shaft is in its final operating position.
- 2.7 **Install and tighten the vessel flange studs or cap screws** to secure the canister seal assembly to the vessel flange or adapter plate. Do not over tighten.
- 2.8 **Tighten the set screws** in the sleeve drive collar uniformly with an Allen wrench.
- 2.9 **Remove the setting devices. Save the setting devices and attachment hardware** for future use.

* Krytox a Registered Trademark of E.I. DuPont

3 Seal Barrier Gas Supply

The standard MD-200 seal design, using #22 carbon rotor faces, is engineered to operate with non-humidified gas supplied to the seal chamber at a consistent pressure 2 bar (25 psig) above the maximum vessel pressure. Nitrogen gas is the barrier fluid of choice. The gas to be used, maximum vessel pressure, shaft speed, temperature, equipment and shaft size must be specified when the seal is ordered.

Note: MD-200 seal designs using #5 carbon rotor faces, still require a conditioned or humidified barrier gas. Nitrogen gas, humidified with a polar compound (water), is the barrier fluid of choice.

4 MD-200 Seal Piping

4.1 **Install piping for the clean nitrogen** to the canister tap. A filter, pressure regulator, flow meter, check valve and pressure indicator are recommended.

Note: A conditioner or humidifier is recommended when using MD-200 with #5 Carbon rotor faces.

4.2 Bearings (optional) have been pre-lubricated during seal assembly.

Recommended Piping for Dual Conditioned Gas Seal

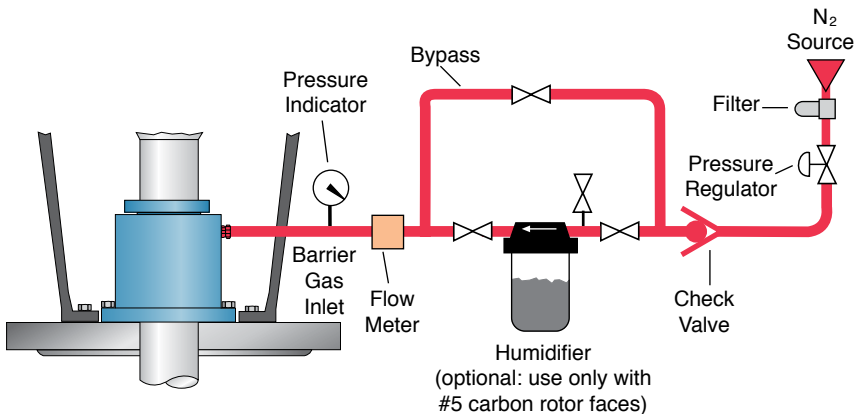

5 Seal Operation

To assure reliable operation of this sealing product, the following operating guidelines should be observed.

- 5.1 **Maintain the gas** (non-conditioned or conditioned) **supply pressure** both while the seal is operating and when the equipment is on standby. Always ensure that there is an adequate flow of barrier gas to the seal.
- 5.2 **Do not exceed the maximum barrier pressure** specified for the seal design. The barrier pressure should be 2 bar (25 psig) above the operating vessel pressure.
- 5.3 **Do not exceed the maximum vessel pressure** specified for the application. This could reduce the recommended vessel to barrier differential pressure which could adversely affect seal performance.
- 5.4 **Do not exceed the maximum vessel temperature** specified for the application. This could exceed the temperature limits of the seal materials of construction applied to the application.
- 5.5 **Do not exceed the seal material corrosion limits.** This seal was designed for the application shown on the seal assembly drawing. Do not exceed the limits of the material alloys and elastomers supplied in its construction.

For special problems encountered during installation, contact your nearest Flowserve Sales and Service Representative or Flowserve Authorized Distributor.

6 Repair

This product is a precision sealing device. The design and dimension tolerances are critical to seal performance. Only parts supplied by Flowserve should be used to repair a seal. To order replacement parts, refer to the part code and B/M number. A spare backup seal should be stocked to reduce repair time.

When seals are returned to Flowserve for repair, **decontaminate the seal assembly** and include an order marked "**Repair or Replace.**" **A signed certificate of decontamination** must be attached.

A Material Safety Data Sheet (MSDS) must be enclosed for any product that came in contact with the seal. The seal assembly will be inspected and, if repairable, it will be rebuilt, tested, and returned.



TO REORDER REFER TO
B/M # _____
F.O. _____

FIS103eng REV 01/08 Printed in USA

***To find your local Flowserve representative
and find out more about Flowserve Corporation,
visit www.flowserve.com***

Flowserve Corporation has established industry leadership in the design and manufacture of its products. When properly selected, this Flowserve product is designed to perform its intended function safely during its useful life. However, the purchaser or user of Flowserve products should be aware that Flowserve products might be used in numerous applications under a wide variety of industrial service conditions. Although Flowserve can provide general guidelines, it cannot provide specific data and warnings for all possible applications. The purchaser/user must therefore assume the ultimate responsibility for the proper sizing and selection, installation, operation, and maintenance of Flowserve products. The purchaser/user should read and understand the Installation Instructions included with the product, and train its employees and contractors in the safe use of Flowserve products in connection with the specific application.

While the information and specifications contained in this literature are believed to be accurate, they are supplied for informative purposes only and should not be considered certified or as a guarantee of satisfactory results by reliance thereon. Nothing contained herein is to be construed as a warranty or guarantee, express or implied, regarding any matter with respect to this product. Because Flowserve is continually improving and upgrading its product design, the specifications, dimensions and information contained herein are subject to change without notice. Should any question arise concerning these provisions, the purchaser/user should contact Flowserve Corporation at any one of its worldwide operations or offices.

© Flowserve Corporation (2011)

USA and Canada

Kalamazoo, Michigan USA
Telephone: 1 269 381 2650
Telefax: 1 269 382 8726

Europe, Middle East, Africa

Dortmund, Germany
Telephone: 49 231 69640
Telefax: 49 231 6964 248

Asia Pacific

Singapore
Telephone: 65 6544 6800
Telefax: 65 6214 0541

Latin America

Mexico City
Telephone: 52 55 5567 7170
Telefax: 52 55 5567 4224