

4 DK75 Position Output Module for DFP17

FCD WCAIM2064-00 (Part 19882)

Installation, Operation and Maintenance

Figure 1 – 120/240 VAC Board shown

4-20 mA Position Output Module option location.
NOTE: Align clipped pin on module with filled socket marked "GND" on circuit board.

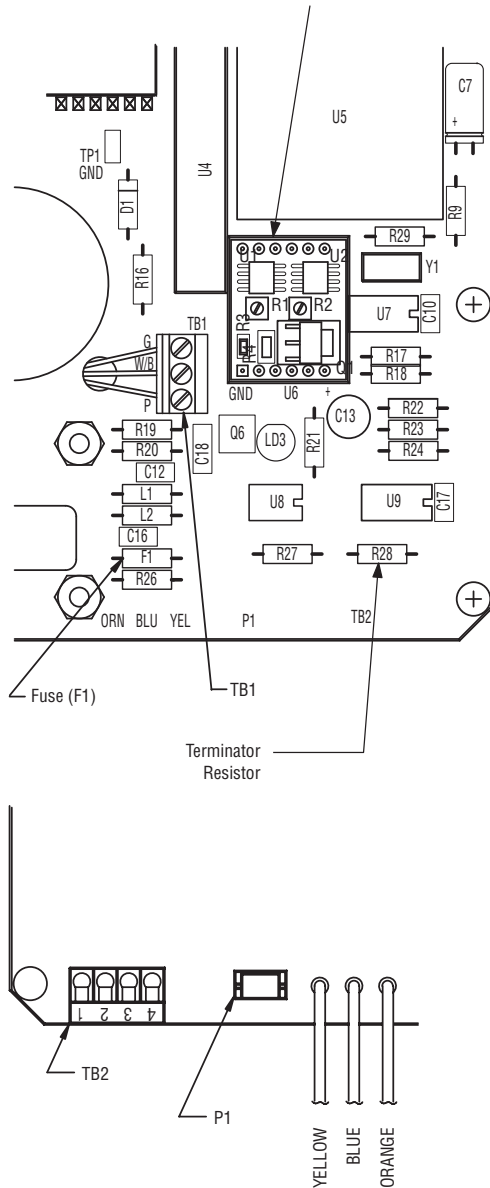

1 Description

The 4 DK75 position output module is designed to be used with and mounted on the Flowserve Worcester DataFlo Digital Positioner (DFP17) Circuit Board in Series 75, 120/240 VAC or 24 VDC actuators. Its output is suited for 4-20 mA DC meter with 0-100% scale (such as General Electric Type GE185), which is not part of the package. If properly calibrated, it indicates actuator shaft position from close (0°, 0%) to open (90°, 100%).

2 Installation

(See Figure 1.)

Parts included in kit:

Item	Qty	Description
1	3	Cable Ties
2	1	4-20 mA Module
3	1	Connector Assembly

The module plugs into the Digital Positioner Board in the area marked "U6" for AC boards and "U4" for DC boards, and a connector assembly connects the output at P1 to the actuator terminal strip.

IMPORTANT: Looking at the top of the module, the pin that has a square soldered area (adjacent to R3 on the module) has been clipped off. This pin must be aligned with the filled socket marked "GND" on the circuit board for proper installation. See Figure 1.



Worcester Actuation Systems

3 Wiring

(See Figures 2, 3 and 4.)

NOTE: All wiring to terminal strip should be inserted only to midpoint of terminal strip.

For 120 VAC board only: Remove yellow wire from terminal 5 and brown wire from terminal 6, disconnect them from N.O. contacts of switches 1 and 2 and discard them. For all voltages: Connect wires of output signal connector assembly from Digital Positioner board connector (P1) such that red wire (+) is wired to terminal 6 and black wire (-) is wired to terminal 5 on the internal side of the terminal strip.

NOTE: Check for Digital Positioner wiring diagram label inside of cover and mark label with the 4-20 mA position output option wiring according to appropriate wiring diagram in Figure 2.

External wiring is between actuator terminal strip and outside power supply and various controls. Common (or negative) wire of the power supply is wired to terminal 1 and hot (or positive) wire of the power supply to terminal 2. An outside position indication meter is wired with positive connection to terminal 6 and negative connection to terminal 5.

Securely tighten all terminal screws. Secure all wires neatly with the cable ties. Keep wiring away from all rotating parts and ensure wiring is not pinched when actuator cover is installed.

The Digital Positioner board 4-20 mA position output module has been calibrated at the factory and should require no further adjustment.

IMPORTANT: The feedback potentiometer is calibrated for only one 90° quadrant of valve operation. If the output shaft is repositioned to another 90° quadrant or if the output shaft is rotated a multiple of 360° from its original position, the feedback potentiometer will no longer be in calibration and must be recalibrated. See the Digital Positioner Instruction, Operation and Maintenance Manual (WCAIM2037).

Figure 2 – Wiring of DFP17 120 VAC Digital Positioner with 4-20 mA position output

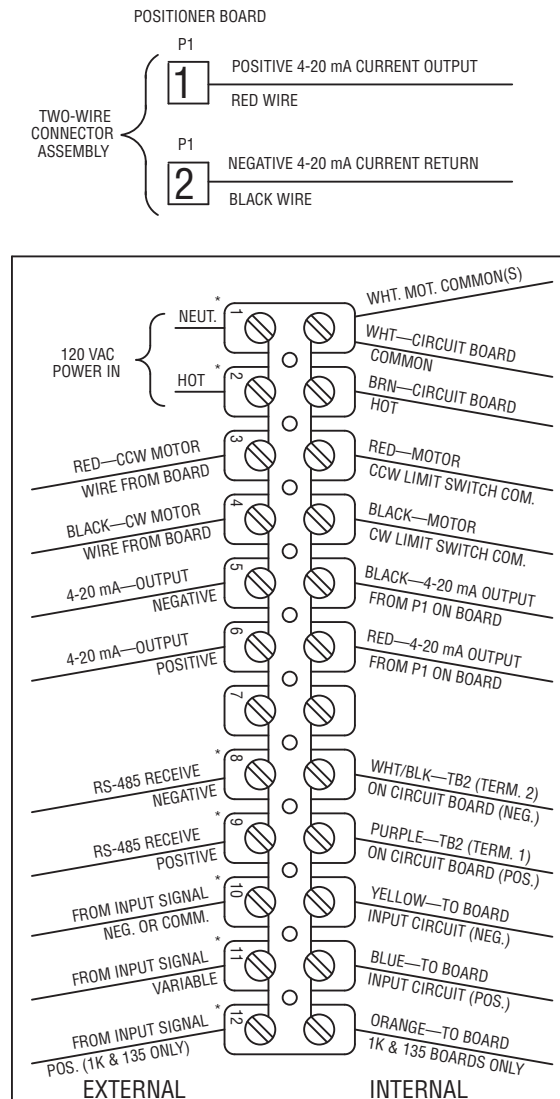

*TERMINALS 1 & 2 (POWER) AND 8 THROUGH 12 (SIGNAL) ON EXTERNAL SIDE ARE FOR USER'S FIELD CONNECTIONS

Figure 3 – Wiring of DFP17 240 VAC Digital Positioner with 4-20 mA position output

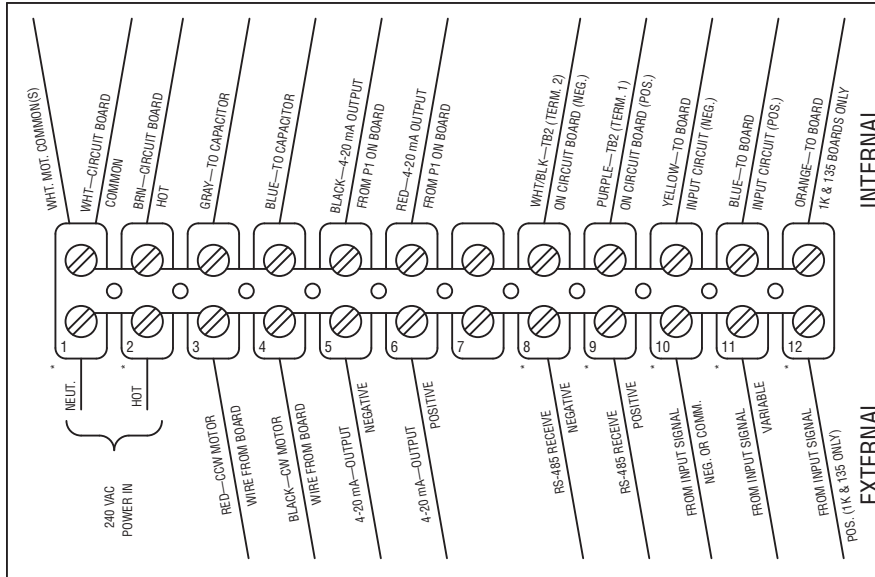
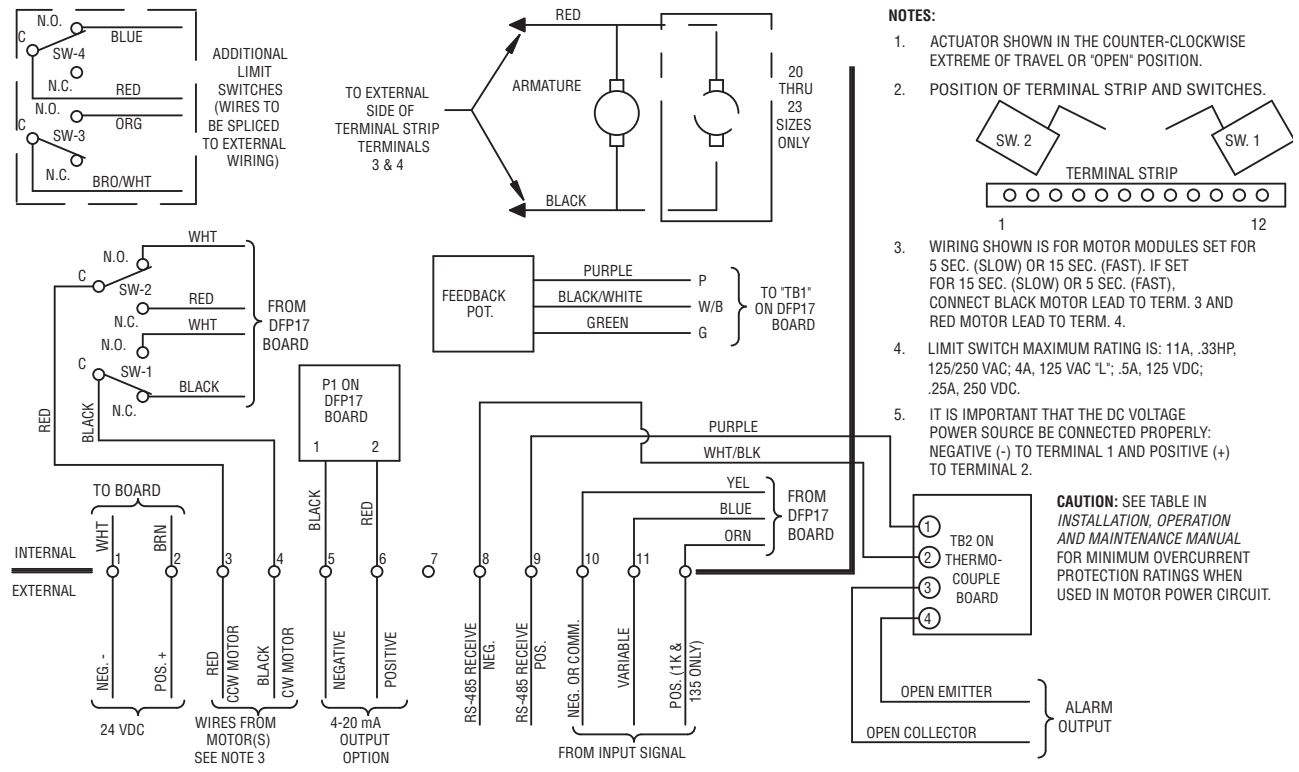

Figure 4 – Wiring of DFP17 24 VDC Digital Positioner with 4-20 mA position output



- NOTES:**
- ACTUATOR SHOWN IN THE COUNTER-CLOCKWISE EXTREME OF TRAVEL OR "OPEN" POSITION.
 - POSITION OF TERMINAL STRIP AND SWITCHES.
 - WIRING SHOWN IS FOR MOTOR MODULES SET FOR 5 SEC. (SLOW) OR 15 SEC. (FAST). IF SET FOR 15 SEC. (SLOW) OR 5 SEC. (FAST), CONNECT BLACK MOTOR LEAD TO TERM. 3 AND RED MOTOR LEAD TO TERM. 4.
 - LIMIT SWITCH MAXIMUM RATING IS: 11A, .33HP, 125/250 VAC; 4A, 125 VAC "L"; .5A, 125 VDC; .25A, 250 VDC.
 - IT IS IMPORTANT THAT THE DC VOLTAGE POWER SOURCE BE CONNECTED PROPERLY: NEGATIVE (-) TO TERMINAL 1 AND POSITIVE (+) TO TERMINAL 2.

CAUTION: SEE TABLE IN INSTALLATION, OPERATION AND MAINTENANCE MANUAL FOR MINIMUM OVERCURRENT PROTECTION RATINGS WHEN USED IN MOTOR POWER CIRCUIT.

Flowserve Corporation has established industry leadership in the design and manufacture of its products. When properly selected, this Flowserve product is designed to perform its intended function safely during its useful life. However, the purchaser or user of Flowserve products should be aware that Flowserve products might be used in numerous applications under a wide variety of industrial service conditions. Although Flowserve can (and often does) provide general guidelines, it cannot provide specific data and warnings for all possible applications. The purchaser/user must therefore assume the ultimate responsibility for the proper sizing and selection, installation, operation, and maintenance of Flowserve products. The purchaser/user should read and understand the Installation Operation Maintenance (IOM) instructions included with the product, and train its employees and contractors in the safe use of Flowserve products in connection with the specific application.

While the information and specifications contained in this literature are believed to be accurate, they are supplied for informative purposes only and should not be considered certified or as a guarantee of satisfactory results by reliance thereon. Nothing contained herein is to be construed as a warranty or guarantee, express or implied, regarding any matter with respect to this product. Because Flowserve is continually improving and upgrading its product design, the specifications, dimensions and information contained herein are subject to change without notice. Should any question arise concerning these provisions, the purchaser/user should contact Flowserve Corporation at any one of its worldwide operations or offices.

For more information about Flowserve Corporation, visit www.flowserve.com or call USA 1-800-225-6989.



Worcester Actuation Systems

FLOWSERVE FLOW CONTROL
Worcester Actuation Systems
5114 Woodall Road
P.O. Box 11318
Lynchburg, VA 24506-1318
Phone: 434-528-4400
Fax: 434-845-9736