

## Primary characteristics

NAF-Torex, High-Performance butterfly valve is available with either metal-to-metal or soft seats. Due to its unique design and triple offset, it closes extremely tight. It can be used both as a control valve and as a shut-off valve. This valve can be supplied in either wafer or lugged versions. The valves are also available in other materials e.g. Carbon steel, and Titanium, other stainless steel materials and in Fire-safe design. Contact NAF for more information.

The valve has:

- triple offset design enables the valve closure to be extremely tight
- small offset results in low operating torque in all control positions, so that low-torque actuators can be used.
- a special disc profile (segment of a toroid) - a principle which eliminates abrasive sliding action when the disc is opening and closing, thus ensuring a longer service life.
- a large mean value of seating angle, so that the disc closes without tending to stick in the closed position, virtually eliminates any disk popping when opening the valve.
- metaloplast bearings. For temperature above 250°C hard chromium stem, direct mounted in the body
- a one-piece valve body of stainless steel.
- a metallic or soft seat ring. Soft seats of three different materials are available.
- the NAF standard for mounting the actuator, which simplifies installation and results in a compact valve/actuator unit.

## CE-marked

According to Pressure Equipment Directive (PED 97/23/EG) module H, category III.

For module H1, category IV contact NAF

## Applications

NAF-Torex can be used both as a control valve and as a shut-off valve, in a wide variety of applications and in different operating modes.

The valve represents a concrete result of our product philosophy which is focused on functionality, high quality and low life cycle costs, and is based on concentrating our range to a limited number of valve types, but all of them suitable for a wide variety of applications.

The excellent characteristics of NAF-Torex are particularly beneficial in arduous control applications, in which difficult media and demanding pressure conditions make severe demands on the design, materials and performance.



## Technical specification

Material: Stainless steel  
 Size range: DN 80-700, 3-28"  
 Pressure ratings: PN 10 - 40  
 ANSI Class 150 and 300

Max. differential pressure:  
 valve closed DN 80-700 25 bar  
 at 70° open valve DN 80 8 bar

DN 100 13 bar  
 DN 125 11 bar  
 (Limitation depending of high velocity with DN 150 6,5 bar  
 big dynamic torque DN 200 4,5 bar  
 at this differential DN 250 3 bar  
 pressure when valve DN 300 2,7 bar  
 is open 70°) DN 350 1,8 bar  
 DN 400 2 bar

DN 500 1,9 bar  
 DN 600, 700 1,8 bar  
 See also page 2

Face-to-face lengths: Wafer type  
 PN 10-25: EN 558-1, serie20  
 ANSI Class 150: API standard 609 Class 150  
 PN 40: EN 558-1, serie 16  
 ANSI Class 300: API standard 609 Class 300  
 Lug type

ANSI Class 150: API Standard 609 Class 150

Installation method: Wafer type and Lug type body  
 Temperature range: -30 - 350°C  
 (see product code)

Test pressure: 1.5 x PN with valve open  
 1.1 x Max. differential pressure with valve closed.

Sealing class: Test medium is water.

Soft seats:  
 ISO 5208-2, Rate A  
 DIN 3230 BN, Leckrate 1  
 Metal seats:  
 IEC 534-4, Class V

**Flow capacities and characteristics (Table 1)  $C_v = 1.16 \times K_v$**

DN	$K_v$ at an opening angle of								
	10°	20°	30°	40°	50°	60°	70°	80°	90°
80	15	32	52	75	100	130	160	200	210
100	21	46	85	115	155	205	260	335	355
125	33	75	122	174	235	327	470	608	675
150	38	95	160	250	360	505	685	885	950
200	60	150	260	430	650	955	1330	1720	1870
250	92	245	430	705	1075	1570	2180	2825	3070
300	140	320	600	1010	1565	2255	3220	4230	4600
350	190	450	835	1350	2120	3085	4500	5910	6425
400	260	600	1110	1795	2735	4020	5900	7780	8550
500	420	980	1820	2940	4480	6580	9660	12740	14000
600	630	1510	2770	4440	6640	9800	14380	18950	20920
700	885	2065	3835	6195	9440	13775	20210	26670	29500

**Max. differential pressure**

Max. differential pressure with valve closed and a temperature up to 35°C is for all sizes 25 bar. At temperatures above 35°C the maximum differential pressure shall be multiplied with a factor "a" according to the curve beside. At 70° open valve is the maximum differential pressure at 35°C limited according to Technical specification page 1. The same reduction of these differential pressure at temperatures above 35°C as for the valve closed is valid. (See the curve beside).

Factor a

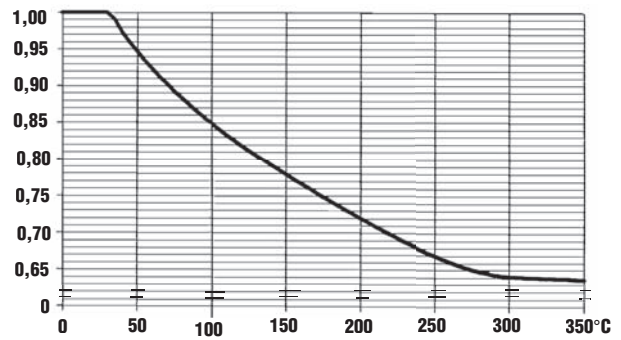

## Operating torque, Nm (Table 2)

DN	Differential pressure (bar)									
	5		10		16		20		25	
	Soft	Hard	Soft	Hard	Soft	Hard	Soft	Hard	Soft	Hard
80	22	-	29	50	38	60	42	67	45	75
100	30	-	38	70	50	85	55	100	65	110
125	50	-	65	95	85	115	95	136	110	150
150	80	-	105	140	130	170	150	200	170	230
200	160	-	205	300	270	350	300	400	350	470
250	280	-	370	500	480	600	540	720	650	850
300	450	-	580	750	750	980	850	1100	960	1250
350	660	-	860	1100	1120	1400	1240	1620	1460	1900
400	940	-	1220	1600	1600	2000	1820	2370	2070	2700
500	1700	-	2200	2800	2800	3500	3140	4090	3610	4700
600	2700	-	3530	4600	4460	5800	5150	6700	5920	7700
700	-	-	-	7560	-	9600	-	10970	-	12600

Soft = Soft seat ring (EPDM, FPM)

Hard = Metal seat ring (Inconel 718) and PTFE seat ring

## Operating torque

The above table specifies the torques necessary for closing the valve to the specified tightness. To achieve the specified tightness with a metal or a PTFE seat ring, the minimum design torque is that corresponding to a differential pressure of 10 bar. At flow through the valve the disc is being affected by dynamic torque which tries to close the valve. At liquid flow and high velocities this may be decisive for selection of actuator size. In general, for this valve, is valid that water velocities below 8 m/s in the pipe line at fully open valve do not give a dynamic torque higher than the closing torques according to the above table.

This means that it is utmost rare that the dynamic torque is decisive for the actuator selection.

In doubts, consult NAF concerning the torque required for actuator selection.

## Sizing of control valves

We have a Windows based valve calculation program which is advanced but very easy to use. This program can be ordered through your NAF representative.

The program is based on calculation formula according to the Standards IEC 534, ISA 575.01 and VDMA 24422.

## Materials

**(Table 3)**

Item	Qty	Part	Material	Sealtype
1	1	Body	EN 1.4408/CF8M	
2	1	Disc	EN 1.4408/CF8M	
3	1	Gland cover	EN 1.4408/CF8M	
4	1	Stem, upper	EN 1.4460	
5	1	Stem, lower	EN 1.4460	
6	1	Clamp ring	DN >250 EN1.4408/CF8M DN<=250 EN1.4436/AISI316	
7	1	Retaining	EN1.4436	
8*	1	Gasket	Graphite	
9*	1	Gasket	Graphite	
10*	1	Seat ring	Inconel 718	05-07,17
11*	1	Seat ring	EPDM	66
12*	1	Seat ring	FPM	55
14*	1	Seat ring	PTFE carbon reinforced	85,86,8A,8B
15* <sub>1)</sub>	1	Clamp ring	DN >250 EN1.4408/CF8M DN<=250 EN1.4436/AISI316	
16*	1	O-ring	EPDM	06,66,86
17*	1	O-ring	EPDM	06,66,86
18*	1	O-ring	FPM	05,55,85
19*	1	O-ring	FPM	05,55,85
20*	1	Backing ring	PTFE	
21*	1	Boxpacking	Graphite	07,17
22	1	Cup spring	EN1.4310	0B, 8B
23	1	Gland cover	EN 1.4408/CF8M	
24A	1	Boxpacking Zebra-CL™	V-ring PTFE	0A, 8A
24B	1	Boxpacking Safeguard	V-ring PTFE liveloaded	0B,8B
26	1	Stem bearing	Metaloplast	
27	1	Stem bearing	Metaloplast	
28	2	Screw	A4	
29	2	Nut	A4	
30	2	Screw	A4	
31 <sub>2)</sub>	2	Screw	A4	
37	1	Washer	Metaloplast	

1) Clamp ring item15 must be included if the valve is to be converted from some other type of seat to a PTFE seat ring.

2) Quantity depending on dimension.

\*) Recommended spare parts.

Other material combinations are available to order - consult your NAF representative.

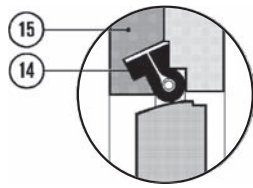

Seal type -85, -86

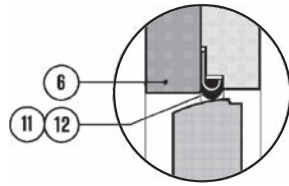

Seal type -55, -66

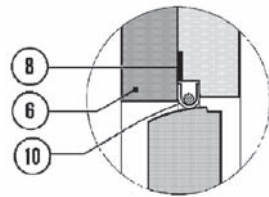

Seal type -05, -06, -07, -17

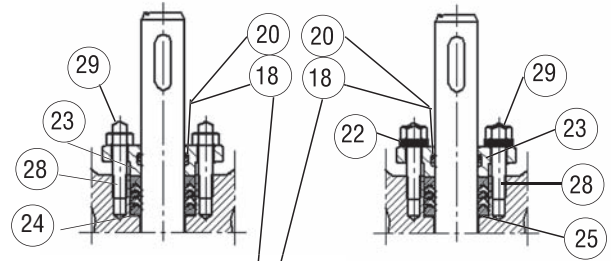

Zebra-CL™ OA, 8A

Safeguard OB, 8B

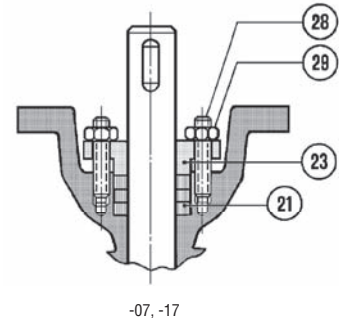
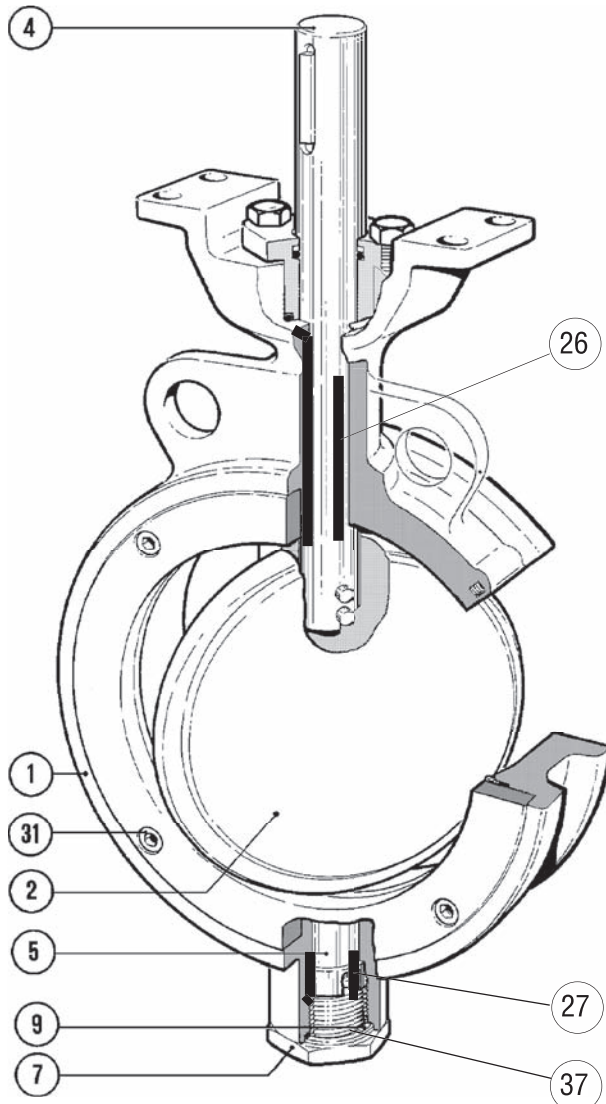
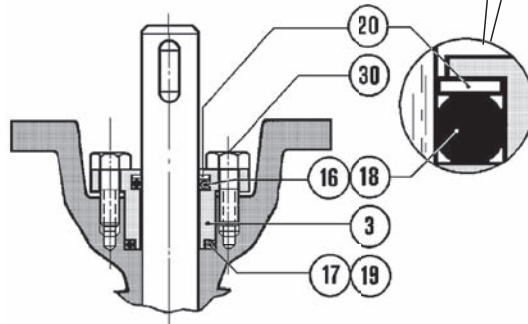

-07, -17

**Dimensions and mass**

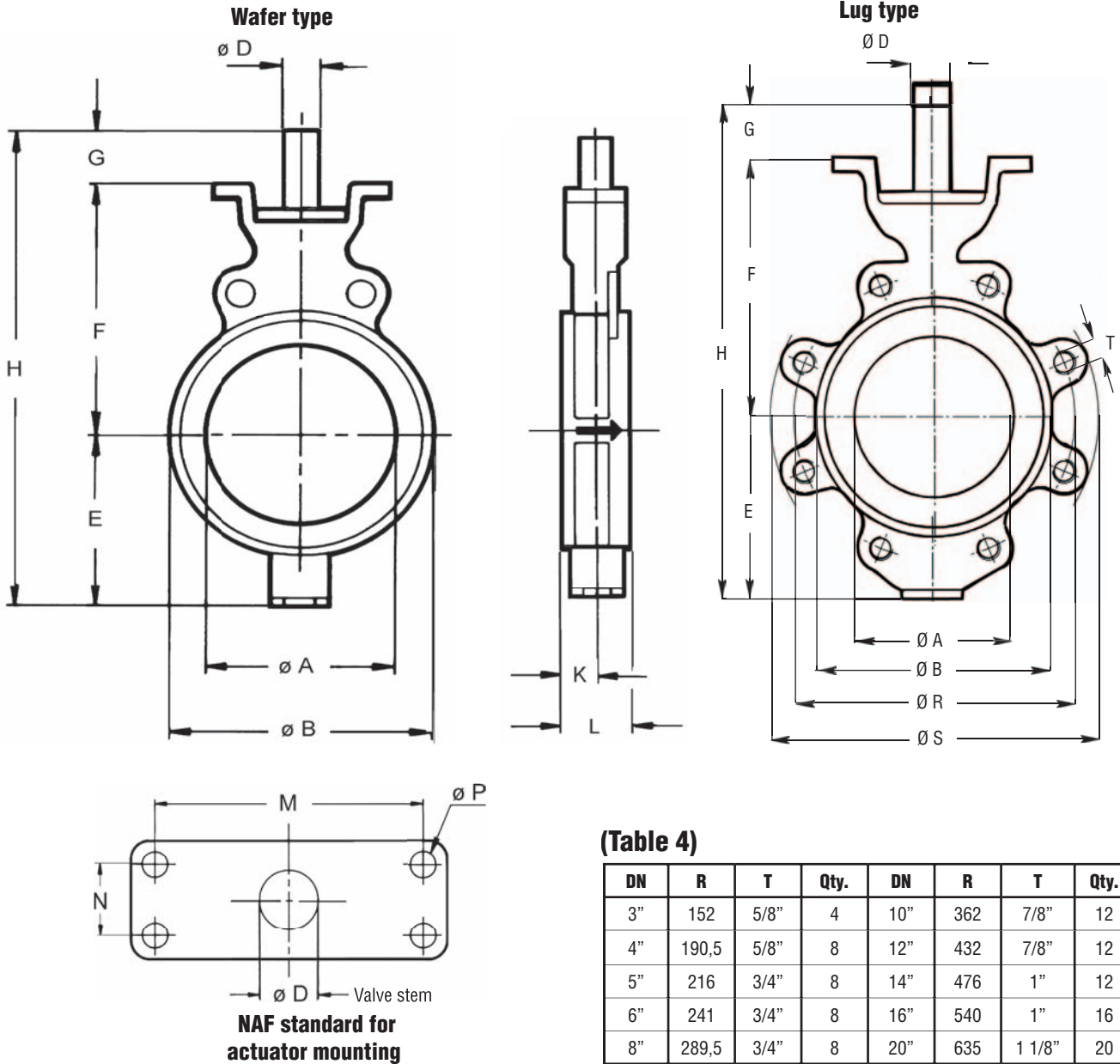

**(Table 4)**

DN	R	T	Qty.	DN	R	T	Qty.
3"	152	5/8"	4	10"	362	7/8"	12
4"	190,5	5/8"	8	12"	432	7/8"	12
5"	216	3/4"	8	14"	476	1"	12
6"	241	3/4"	8	16"	540	1"	16
8"	289,5	3/4"	8	20"	635	1 1/8"	20

**PN 10-25, ANSI Class 150 Wafer type and Lug type (Table 5)**

DN	A	B	D	E	F	G	H	K	L		M	N	P	S	Mass, kg	
									Wafer	Lug					Wafer	Lug
80	83	132	20	105	157	43	305	23	46	48	115	30	11	182	5	7
100	105	160	25	123	175	50	348	26	52	54	115	30	11	223	7	12
125	117	190	25	129	190	50	369	28	56	-	115	30	11	-	9	-
150	143	215	25	141	205	50	396	28	56	57	115	30	11	281	11	19
200	194	270	30	172	243	59	474	29	60	64	160	40	14	339	20	33
250	242	325	35	207	276	65	548	31	68	71	160	40	14	412	29	46
300	292	375	40	239	315	80	634	34	78	81	214	60	18	480	44	72
350	326	435	40	264	354	80	698	33	78 <sup>1)</sup>	92	214	60	18	526	63	101
400	372	485	50	296	394	93	783	43	102	102	214	60	18	592	94	140
500	472	590	60	382	459	111	952	55	127	127	214	60	18	687	140	210
600	566	690	70	474	541	131	1146	63	154	154	277	115	33	830	281	400
700	670	802	80	555	584	149	1288	74,5	165	-	277	115	33	-	420	

All dimensions in mm

1) ANSI Class 150 standard for size 14" specify L = 92 mm

## PN 40, ANSI 300 Wafer type (Table 6)

DN	A	B		D	E		F		G	H		K		L		M	N	P	Mass, kg	
		PN	ANSI		PN	ANSI	PN	ANSI		PN	ANSI	PN	ANSI	PN	ANSI				PN	ANSI
80	83	139	143	20	105	123	157	157	43	305	323	41	25	64	48	115	30	11	7	6
100	105	164	175	25	123	123	175	175	50	348	348	38	28	64	54	115	30	11	9	8
125*	117	190	-	25	129	-	190	-	50	369	-	35	-	70	-	115	30	11	14	-
150	143	218	244	25	141	156	205	205	50	396	411	38	31	76	59	115	30	11	16	13
200	194	285	301	30	182	198	253	253	59	494	510	45	42	89	73	160	40	14	29	25
250	242	335	355	35	226	226	300	276	65	591	567	57	42	114	83	160	40	14	52	42
300	292	395	415	40	259	271	335	335	80	674	686	57	48	114	92	214	60	18	63	49
350	326	450	478	40	297	297	354	354	80	731	731	60	59	127	117	214	60	18	98	92
400	372	532	532	50	345	345	394	394	93	832	832	73	66	140	133	214	60	18	129	120
500	472	624	624	60	410	410	459	459	111	980	980	76	83	152	159	214	60	18	163	170

\* DN 125 only available as PN 40

## Actuators

NAF-Torex is available with hand levers or with pneumatic or electric actuators and accessories.

Use the following tables for selecting the hand levers and standard pneumatic actuators.

If other pneumatic or electric actuators are required, consult your NAF representative.

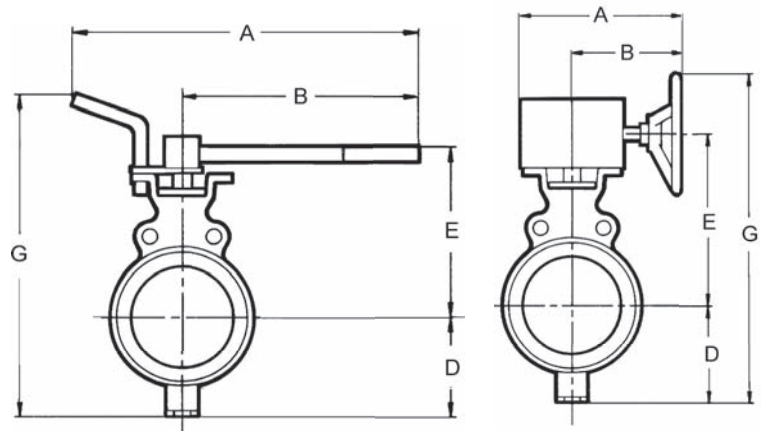

## NAF-Torex with hand levers (Table 7)

Valve size DN	Max dp bar		NAF No.	Dimensions, mm					Mass kg <sup>1)</sup>
	Soft seat	Hard seat <sup>3)</sup>		A	B	D	E	G	
Hand lever as per Fk 70.51									
80	25	25	791020-2	500	350	105	197	382	7
100	25	25	-3	500	350	123	215	418	9
125	25	20 <sup>4)</sup>	-3	500	350	129	230	439	11
150	12	-	-3	500	350	141	245	466	13
Worm gear actuator as per Fk 70.76 <sup>2)</sup>									
80	25	25	791051-11020	249	174	105	191	396	9
100	25	25	791051-11025	249	174	123	209	432	11
125	25	25	791051-11025	249	174	129	224	453	13
150	25	25	791051-11025	249	174	141	239	480	15
200	25	25	791051-22030	328	243	172	286	608	29
250	25	25	791051-22035	328	243	207	319	676	38
300	25	25	791051-33040	416	291	239	365	804	61
350	25	25	791051-33040	416	291	264	404	868	80
400	23	16	791051-33050	416	291	296	459	955	111
400	25	25	791051-43050	507	337	296	449	995	126
500	25	19	791051-43060	507	337	382	514	1146	172
500	25	25	791051-53060	591	421	382	514	1096	178
600	25	19	791051-55070	591	421	474	621	1295	319
600	25	25	791051-65070	697	487	474	630	1404	348
700	-	25	791051-65080	697	487	555	658	1513	487

1) Wafer type PN 10-25, ANSI Class 150  
 2) Available with locking device. Contact NAF.  
 3) Hard seat = Metal and PTFE-seat  
 4) Metal seat only (PTFE choose gear)

All dimensions in mm

**NAF-Torex valves with pneumatic actuators (Table 8)**

The below stated dP apply for clean media type water.  
For other media contact NAF, see also page 2.

Valve size DN	Max. dp bar at supply of						NAF No.	Dimensions, mm									Mass kg <sup>2)</sup>
	4 bar		5 bar		6 bar			A	B	C	D	E	F	G <sup>1)</sup>	H	R	
	Soft seat	Hard seat <sup>3)</sup>	Soft seat	Hard seat <sup>3)</sup>	Soft seat	Hard seat <sup>3)</sup>											
<b>Double-acting as per Fk 74.59</b>																	
80	25	25	25	25	25	25	791290-0220	370	185	80	105	207	259	459	31	70	9
100	25	12	25	18	25	25	-0225	370	185	80	123	225	277	495	31	70	11
100	25	25	25	25	25	25	-1225	490	245	100	123	230	287	505	40	70	13
125	12	-	20	11	25	18	-0225	370	185	80	129	240	292	516	31	70	13
125	25	25	25	25	25	25	-1225	490	245	100	129	245	302	526	40	70	15
150	6	-	10	-	14	-	-0225	370	185	80	141	255	307	543	31	70	15
150	22	13	25	20	25	25	-1225	490	245	100	141	260	317	553	40	70	17
150	25	25	25	25	25	25	-2125	700	350	145	141	280	353	589	63	70	28
200	20	12	25	18	25	25	-2130	700	350	145	172	318	391	658	63	80	37
200	25	25	25	25	25	25	-2230	700	350	145	172	318	391	658	63	80	37
250	7	-	12	-	17	-	-2135	700	350	145	207	351	424	726	63	80	46
250	25	17	25	22	25	25	-2235	700	350	145	207	351	424	726	63	80	46
250	25	25	25	25	25	25	-3135	820	410	200	207	376	476	778	75	80	58
300	12	-	20	10	25	16	-2240	700	350	145	239	390	463	797	63	120	61
300	25	20	25	25	25	25	-3140	820	410	200	239	415	515	849	75	120	73
350	5	-	9	-	12	-	-2240	700	350	145	264	429	502	861	63	120	80
350	14	-	21	14	25	20	-3140	820	410	200	264	454	554	913	75	120	92
350	25	25	25	25	25	25	-3240	820	410	200	264	454	554	913	75	120	92
400	8	-	12	-	16	10	-3150	820	410	200	296	494	593	984	75	120	123
400	25	16	25	23	25	25	-3250	820	410	200	296	494	593	984	75	120	123
400	25	25	25	25	25	25	791390-4250	1110	555	260	596	522	654	1045	100	120	139
500	7	-	10	-	18	12	-4160	1110	555	260	382	587	719	1196	100	120	185
500	25	20	25	25	25	25	-4260	1110	555	260	382	587	719	1196	100	120	185
600	12	-	19	12	25	16	-4270	1110	555	260	474	717	801	1370	100	150	326
600	25	25	25	25	25	25	-5170	1680	840	395	474	723	865	1440	150	150	501
700	-	11	-	17	-	24	-5180	1680	840	395	555	766	964	1564	150	-	-
700	-	25	-	25	-	25	-5280	1680	840	395	555	766	964	1564	150	-	-
<b>Single-acting, spring to close as per Fk 74.59</b>																	
80	-	-	12	-	12	-	791292-0220	455	270	80	105	207	529	459	31	70	10
80	25	25	25	25	25	25	-1220	635	390	100	105	212	269	469	40	70	14
100	-	-	5	-	5	-	-0225	455	270	80	100	225	277	495	31	70	12
100	25	14	25	14	25	14	-1225	635	390	100	123	230	287	505	40	70	16
100	25	25	25	25	25	25	-2225	890	540	145	123	250	323	541	63	70	30
125	16	-	16	-	16	-	-1225	635	390	100	129	245	302	526	40	70	18
125	25	25	25	25	25	25	-2225	890	540	145	129	265	338	562	63	70	32
150	6	-	6	-	6	-	-1225	635	390	100	141	245	317	553	40	70	20
150	25	25	25	25	25	25	-2225	890	540	145	141	280	353	589	63	70	34
200	22	15	22	15	22	15	-2230	890	540	145	172	318	391	658	63	80	43
200	25	25	25	25	25	25	-3230	1050	640	200	172	343	443	710	75	80	63
250	8	-	8	-	8	-	-2235	890	540	145	207	351	424	726	63	80	52
250	25	25	25	25	25	25	-3235	1050	640	200	207	376	476	778	75	80	72
300	25	17	25	17	25	17	-3240	1050	640	200	239	415	515	849	75	120	87
300	25	25	25	25	25	25	791392-4240	1520	965	260	239	443	575	909	100	120	144
350	13	-	13	-	13	-	791292-3240	1050	640	200	264	454	554	913	75	120	106
350	25	25	25	25	25	25	791392-4240	1520	965	260	264	482	614	973	100	120	163
400	6	-	6	-	6	-	791292-3250	1050	640	200	296	494	593	984	75	120	137
400	25	18	25	18	25	18	791392-4250	1520	965	260	596	522	654	1045	100	120	194
400	25	25	25	25	25	25	-5250	2210	1370	395	296	559	724	1115	150	120	559
500	10	-	10	-	10	-	-4260	1520	965	260	382	587	719	1196	100	120	240
500	25	25	25	25	25	25	-5260	2210	1370	395	382	624	789	1266	150	120	675
600	25	25	25	25	25	25	-5270	2210	1370	395	474	723	936	1440	150	150	766
700	-	12	-	12	-	12	-5280	2210	1370	395	555	766	964	1564	150	-	-

1) Including NAF valve positioner

2) Wafer type PN 10-25, ANSI Class 150

3) Hard seat = Metal and PTFE-seat

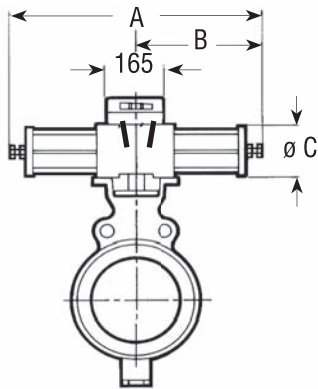

NAF 791290/791390

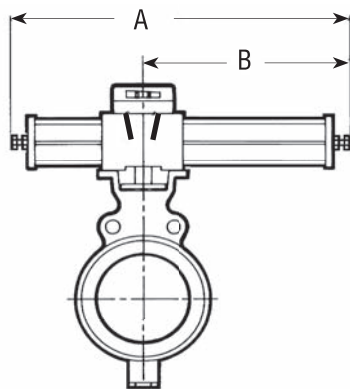

NAF 791292/791392

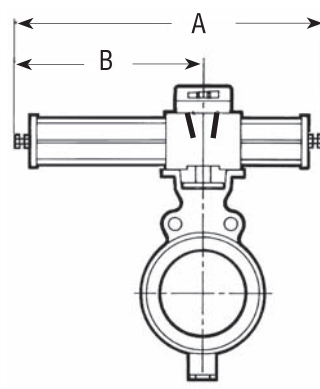

NAF 791294/791394

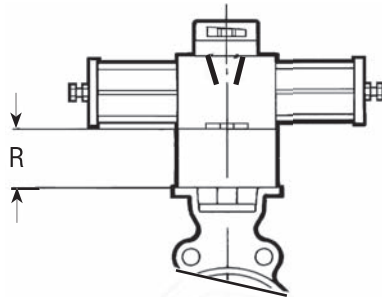
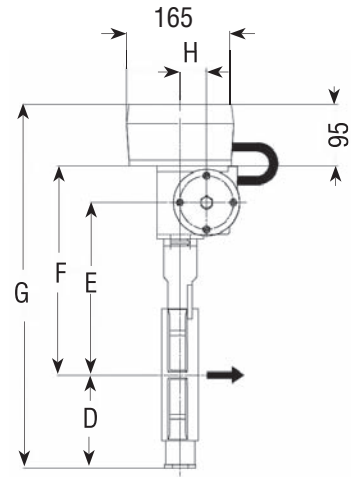

For high-level actuator installation, (design -17) a spacer with height R is also required

**(Table 9)**

The below stated dP apply for clean media type water. For other media contact NAF, see also page 2.

Valve size DN	Max. dp bar at supply of						NAF No.	Dimensions, mm								Mass kg <sup>2)</sup>	
	4 bar		5 bar		6 bar			A	B	C	D	E	F	G <sup>1)</sup>	H		R
	Soft seat	Hard seat <sup>3)</sup>	Soft seat	Hard seat <sup>3)</sup>	Soft seat	Hard seat <sup>3)</sup>											
<b>Enkelverkande, fjäder öppnar enl. Fk 74.59</b>																	
80	-	-	7	-	18	18	791294-0220	455	270	80	105	207	259	459	31	70	10
80	5	-	25	20	25	25	-1220	635	390	100	105	212	269	469	40	70	14
80	25	25	25	25	25	25	-2220	890	540	145	105	232	305	505	63	70	28
100	-	-	25	-	25	20	-1225	635	390	100	123	230	287	505	40	70	16
100	25	25	25	25	25	25	-2225	890	540	145	123	250	323	541	63	70	30
125	-	-	11	-	22	14	-1225	635	390	100	129	245	302	526	40	70	18
125	20	18	25	25	25	25	-2225	890	540	145	129	265	338	562	63	70	32
150	10	-	25	25	25	25	-2225	890	540	145	141	280	353	589	63	70	34
200	-	-	20	-	25	20	-2230	890	540	145	172	318	391	658	63	80	43
200	22	18	25	25	25	25	-3230	1050	640	200	172	343	443	710	75	80	63
250	9	-	25	25	25	25	-3235	1050	640	200	207	376	476	778	75	80	72
250	25	22	25	25	25	25	791394-4235	1520	965	260	207	404	536	828	100	80	129
300	-	-	20	14	25	20	791294-3240	1050	640	200	239	415	515	849	75	120	87
300	15	10	25	25	25	25	791394-4240	1520	965	260	239	443	575	909	100	120	144
350	-	-	10	-	22	10	791294-3240	1050	640	200	264	454	554	913	75	120	106
350	8	-	25	25	25	25	791394-4240	1520	965	260	264	482	614	973	100	120	163
400	-	-	5	-	12	-	791294-3250	1050	640	200	296	494	593	984	75	120	137
400	-	-	22	12	25	25	791394-4250	1520	965	260	296	522	654	1045	100	120	194
400	25	25	25	25	25	25	-5250	2210	1370	395	296	559	724	1115	150	120	559
500	-	-	6	-	25	12	-4260	1520	965	260	382	587	719	1196	100	120	240
500	18	12	25	25	25	25	-5260	2210	1370	395	382	624	789	1266	150	120	675
600	-	-	-	-	6	-	-4270	1520	965	260	474	669	801	1370	100	150	381
600	6	-	25	22	25	25	-5270	2210	1370	395	474	723	936	1440	150	150	766
700	-	-	-	10	-	14	-5280	2210	1370	395	555	766	964	1564	150	-	-

1) Including NAF valve positioner

2) Wafer type PN 10-25, ANSI Class 150

3) Hard seat = Metal and PTFE-seat

### Accessories

NAF's pneumatic actuators, see data sheet Fk74.59 can be equipped with a large number of accessories.

The following are included in NAF's standard programme and are suitable for direct mounting to NAF pneumatic actuators.

### Valve positioner

Pneumatic and electro-pneumatic valve positioner, see data sheet Fk41.82.

Intelligent valve positioner, see data sheet Fk41.85.

### Solenoid valves

See data sheet Fk79.17.

### Electrical position indication

See data sheet Fk79.10.

### Terminal box

The actuator can be equipped with a junction box (part No. 34920930) of cast aluminium containing terminal blocks for connecting the solenoid valve and position sensors.

### Fugitive emissions Approval, EN ISO15848-1

NAF has certified some of our valves with a new stem sealing, according to EN ISO 15848-1 (this new standard will replace the old TA-luft standard). The packing box solution is with a V-ring set. The new packing set is live loaded with spring cups and equipped with an o-ring above the stem packing. Following valves have been certified in the first test.

Classification according to test results is

**ISO-FE BH - CC1 - SSA0 - t200°C PN25**

### Classification classes:

BH Tightness class B, test fluid Helium  
CC1 20000 mechanical cycles, 2 thermal cycles.  
SSA0 Without shaft seal adjustments during test  
T200°C Temperature Class  
PN25 Endurance Class.

### Certified Products

Wafer:

DN80-DN200

Flanged :

PN10 DN200 to DN300

PN16 DN80 to DN300

ANSI150 1" to 12"

PN25 DN200 to DN300

For other sizes and pressure classes contact NAF.

**Product code:** i.g 2383BB-0150-0B

Code	Seat sealing	Stem sealing
<b>B</b>	PTFE	Safeguard

## Other versions

### - Degreased for oxygen

Before assembly, all valve parts are degreased in trichlorethylene vapour in accordance with quality instructions Qi-207. The valve is assembled and packed so that no oil or grease will enter the valve.

*Product code: D*

### - PFM, Isolast® O-ring stem seal

For temperatures up to 250°C the standard O-rings item 16-19 as per Fk 41.42GB can be replaced by PFM, Isolast®. For higher temperatures, contact NAF.

*Product code: K*

### - Stem sealing for vacuum

For vacuum the stem sealing O-ring kit is turned to be tight against the pressure from outside.

For applications with alternating vacuum/overpressure is the overpressure limited to 2 bar.

*Product code: V*

### - Explosive atmosphere acc. to Directive 94/9/EC ATEX

NAF-Torex is certified according to ATEX 94/9/EC in

 II 2 G/D c

*Product code: XA*

- Drilling according to JIS 10K
- Internal O-rings for protecting the stem bearing
- Internally polished body and disc
- Titanium version
- Fire-Safe
- Other materials

Contact NAF for more information

**Product code for NAF-Torex**

Example:

**Code**    23 8 3 B B - 0150 - 06  
                   1    2    3    4    5            6        7

- 1. Valve type**  
23 NAF-Torex
- 2. Material**  
8 Stainless steel CF8M
- 3. Pressure rating**

2	PN 10	(DN 200-700) <sup>1)</sup>
3	PN 16	(DN 100-700) <sup>2)</sup>
4	ANSI Class 150	(Size 3"-28")
5	PN 25	(DN 80-700)
6	PN 40	(DN 80-500)
7	ANSI Class 300	(Size 3"-20")
- 4. Stem bearing**

	<b>Body</b>	<b>Stem</b>
<b>A</b>	-	Hard chrome plated
<b>B</b>	Metaloplastbearing (max 250°C)	-
- 5. Installation method**

<b>B</b>	Wafer type
<b>L</b>	Lug type body ANSI Class 150 (for PN classes cont. NAF)
- 6. Size**

DIN-version	ANSI-version
DN	Size
<b>0080</b>	80 <b>0003</b> 3"
<b>0100</b>	100 <b>0004</b> 4"
<b>0125</b>	125 <b>0005</b> 5"
<b>0150</b>	150 <b>0006</b> 6"
<b>0200</b>	200 <b>0008</b> 8"
<b>0250</b>	250 <b>0010</b> 10"
<b>0300</b>	300 <b>0012</b> 12"
<b>0350</b>	350 <b>0014</b> 14"
<b>0400</b>	400 <b>0016</b> 16"
<b>0500</b>	500 <b>0020</b> 20"
<b>0600</b>	600 <b>0024</b> 24"
<b>0700</b>	700 <b>0028</b> 28"
- 7. Seals**

Seat ring	Stem seal	Max. temp. °C
<b>0A</b>	Inconel Zebra-CL™	250
<b>0B</b>	Inconel Safeguard	250
<b>05</b>	Inconel FPM	200
<b>06</b>	Inconel EPDM	200
<b>07</b>	Inconel Graphite (box)	350 <sup>3)</sup>
<b>17</b>	Inconel Graphite (box) (high level actuator inst)	350 <sup>3)</sup>
<b>55</b>	FPM FPM	90
<b>66</b>	EPDM EPDM	130
<b>8A</b>	PTFE Zebra-CL™	250
<b>8B</b>	PTFE Safeguard	250
<b>85</b>	PTFE FPM	200
<b>86</b>	PTFE EPDM	200

1) DN 80 has the same flange dimensions in PN 10, 16 and 25, choose PN 25  
 DN 100-150 has the same flange dimensions in PN 10 and 16, choose PN 16  
 2) DN 80 choose PN 25  
 3) Max 250°C with metaloplast bearings