

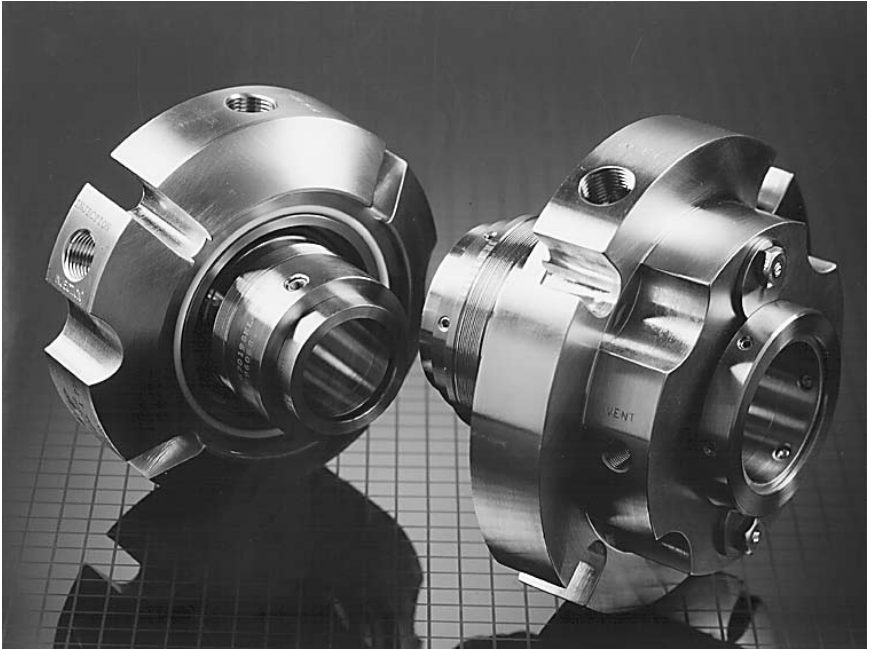

Installation Instructions

Uniseal Series

Cartridge metal bellows single and dual seals



Description

The Uniseal metal bellows seal series consists of:

Uniseal I - Single seals for standard bore seal chambers

Uniseal I Plus - Single seals for enlarged bore seal chambers

Uniseal II - Dual seal for standard bore seal chambers

Uniseal II Plus - Dual seal for enlarged bore seal chambers

1 Equipment Check

- 1.1 **Follow plant safety regulations** prior to equipment disassembly including, but not limited to, the following:
 - Lock out motor and valves.
 - Wear designated personal safety equipment.
 - Relieve any pressure in the system.
 - Consult plant MSDS files for hazardous material regulations.
- 1.2 **Disassemble pump** in accordance with equipment manufacturer's instructions and remove sealing arrangement.
- 1.3 **Check seal documentation** for seal design and materials of construction. Verify that the Uniseal is designed for the equipment being repaired.
- 1.4 **Check seal assembly drawing** for any modifications required to the equipment before installation and act accordingly.
- 1.5 **Check shaft or pump sleeve OD, seal chamber depth, seal chamber bore, distance to the first obstruction, gland pilot and gland bolting** to ensure they are dimensionally within the tolerances shown on the seal assembly drawing. Check gland bolt length to ensure adequate thread engagement for the actual seal gland.
- 1.6 **Thoroughly inspect and clean** the seal chamber and shaft or pump sleeve. Inspect for corrosion or any defects. Remove all burrs, cuts, dents or defects that might damage gaskets or allow a leak path. Replace worn shaft or pump sleeve. **Remove sharp edges** from keyways and threads.
- 1.7 **Check equipment requirements** as described in **Figure 1**. Any reading greater than what is allowed must be brought within specifications.
- 1.8 **Handle the Uniseal with care**; it is manufactured to precise tolerances. The seal faces are of special importance and should be kept perfectly clean at all times.
- 1.9 **Tools needed** for installation: An open-end wrench and torque wrench sized for the gland bolt nuts; a torque wrench for the set screws. All other tools are provided.

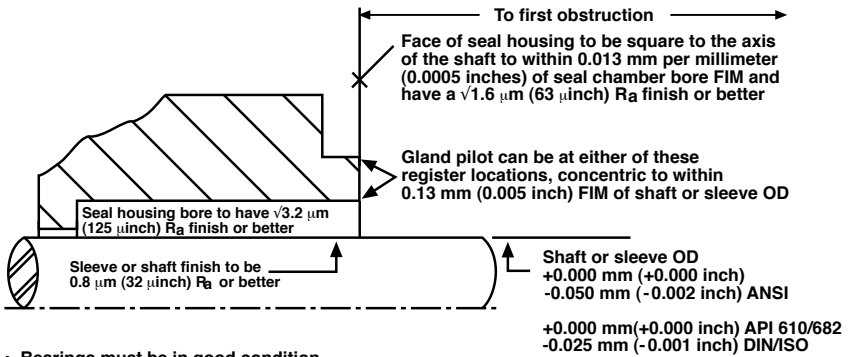

- Bearings must be in good condition
- Maximum lateral or axial movement of shaft (end play) = 0.25 mm (0.010 inch) FIM
- Maximum shaft runout at face of seal housing = 0.05 mm (0.002 inch) FIM
- Maximum dynamic shaft deflection at seal housing = 0.05 mm (0.002 inch) FIM

2 Uniseal Installation

Note: No seal setting measurements are needed to install the seal. Instructions are for end-suction back pull-out pumps. Modification of these procedures may be required for other style pumps. Consult Flowserve for installation support.

- 2.1 **Lubricate the shaft** or pump sleeve lightly with silicone lubricant unless otherwise specified.
- 2.2 **Tighten the setting device cap screws** to ensure they are tight before installation.
- 2.3 **Slide the Uniseal cartridge** onto the shaft or pump sleeve with the setting devices toward the bearing housing. See Figure 2.
- 2.4 **Install the seal chamber** and bolt it in place on the bearing frame. See Figure 3.
- 2.5 **Position the Uniseal** with the gland tight against the seal chamber.

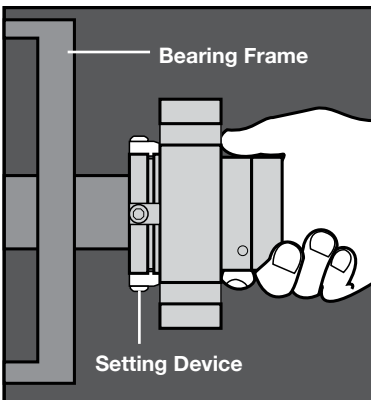

Figure 2

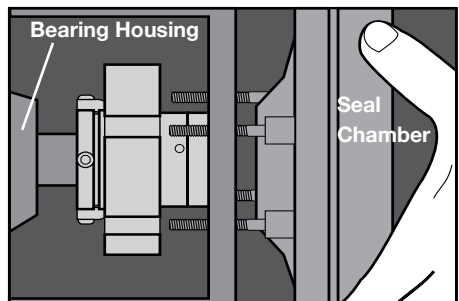

Figure 3

- 2.6 **Orient the Uniseal** with the ports aiming as shown on the seal assembly drawing. See Section 3 for Piping Recommendations.
- 2.7 **Tighten the gland nuts evenly in a diagonal sequence.** Do not over-tighten the gland nuts, as this can warp seal parts and cause leakage. Confirm adequate thread engagement before final torque setting.

Recommended Uniseal minimum **gland nut torque** by size range:

Seal mm	25 - 50	54 - 67
Size (inch)	(1.000 - 2.000)	(2.125 - 2.625)
Torque	20 N-m (15 ft-lbs)	27 N-m (20 ft-lbs)

2.8 Assemble the equipment per manufacturer specifications. Avoid pipe strain. Align the coupling per manufacturer specifications.

2.9 With the impeller, shaft, coupling and bearings in their final operating position, tighten the drive collar set screws. See Figure 4.

Recommended Uniseal minimum **set screw torque** by size range:

Seal mm	25 - 60	67
Size (inch)	(1.000 - 2.500)	(2.625)
Torque	4.5 N-m (40 in-lbs)	13.5 N-m (120 in-lbs)

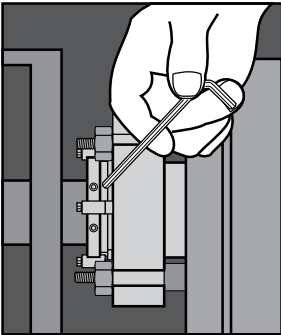

Figure 4

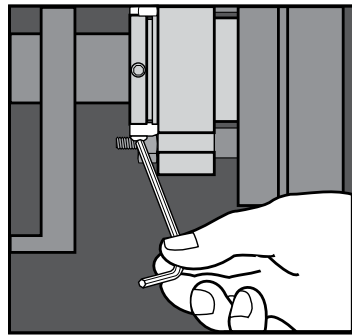

Figure 5

- 2.10 **Remove the setting devices** from the drive collar by loosening the cap screws. See Figure 5. Save the setting devices and fasteners for future use when the pump impeller is reset or when the seal is removed for repairs.
- 2.11 **Turn the shaft** by hand to ensure unobstructed rotation.
- 2.12 See **Operational Recommendations** before start-up.

3 Piping Recommendations

3.1 Install and maintain an adequate piping plan. The Uniseal requires a clean, cool environment for maximum seal life. Typical piping plans are listed below. Contact Flowserve for additional piping plan information or technical support.

- Plan 11: default inner seal flush from pump discharge on horizontal pumps (single seals)
- Plan 13: default inner seal flush and vent from pump suction on vertical pumps (single seals)
- Plan 21: inner seal flush from pump discharge through a cooler for use with hot products (single seals)
- Plan 32: inner seal clean external flush for use with abrasive products or products that are incompatible with the seal (single seals)
- Plan 52: dual seal circulation through a low pressure reservoir (dual seals)
- Plan 53: dual seal circulation through a pressurized reservoir (53A), finned tube array (53B) or piston accumulator (53C) (dual seals)
- Plan 62: external quench on atmospheric side of seal (single seals)

3.2 For **single seals**, follow the port connections listed below, see Figure 6. **Quench and Drain ports on single seals should be plugged if not used** as a good housekeeping practice.

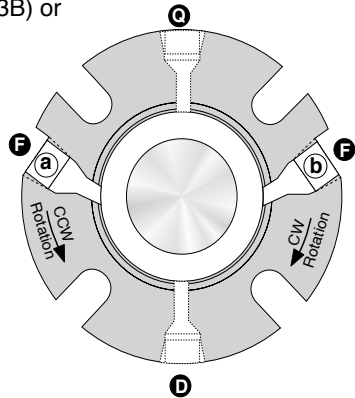

Single seal port connections

Figure 6

For Plans 11, 21 and 32:

Shaft Rotation (from exposed end of gland)	Inlet	Plugged Port
Clockwise (CW)	Port (b)	Port (a)
Counterclockwise (CCW)	Port (a)	Port (b)

For Plan 13:

Shaft Rotation (from exposed end of gland)	Outlet	Plugged Port
Clockwise (CW)	Port (a)	Port (b)
Counterclockwise (CCW)	Port (b)	Port (a)

- 3.3 For **dual seals**, follow the port connections listed below, see Figure 7. Uniseals are unidirectional and piping the correct inlet and outlet is important to proper circulation. The liquid barrier inlet should draw from the bottom of the support system while the liquid barrier outlet feeds the top of the system. After venting, plug the vent port.

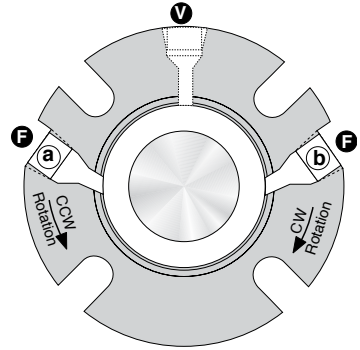

Dual seal port connections

Figure 7

For Plans 52 and 53:

Shaft Rotation (from exposed end of gland)	Inlet	Outlet
Clockwise (CW)	Port b	Port a
Counterclockwise (CCW)	Port a	Port b

- 3.4 For **dual pressurized seal (double seal) operation**, supply a clean, compatible barrier fluid at a pressure at least 1.7 bar (25 psi) above the seal chamber pressure. See Figure 8. The pressure of the barrier fluid must not exceed the recommended maximum pressure.

Dual pressurized (Plan 53A) Uniseal with Supply Tank Figure 8

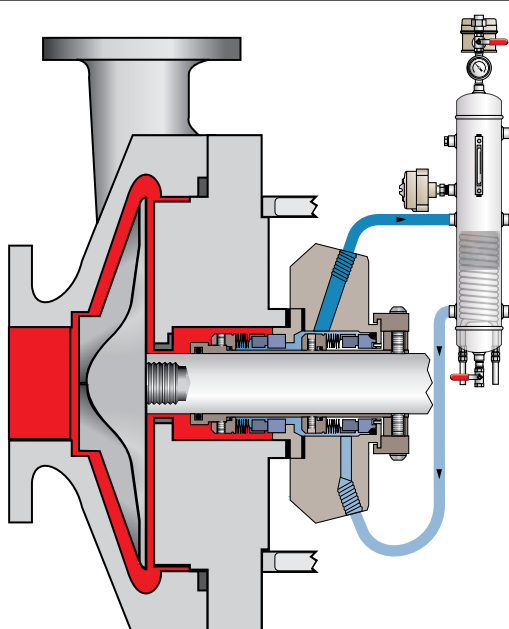

Image is not to scale

- 3.5 For **dual unpressurized (tandem seal) operation**, supply a clean, compatible buffer fluid at a pressure below the seal chamber pressure. The pressure in the seal chamber must not exceed the recommended maximum pressure.
- 3.6 **Dual seal recommendation:** For enhanced seal performance and reduced coking, use **DuraClear** as a barrier fluid. Refer to DuraClear brochure FSD123 or contact a Flowserve representative for further details.

4 Operational Recommendations

- 4.1 **Remove lock outs** on equipment and valves.
- 4.2 **Do not start up the pump dry** to check motor rotation or for any other reason. Open valves to flood pump with product fluid. Ensure that the seal flush or support system is operating. Vent air from the casing of the pump and the seal chamber before start-up.
- 4.3 **Observe the start-up.** If the seal runs hot or squeals, check the seal flush system. Do not allow the pump to run for any extended time if the seal gets hot or squeals.
- 4.4 **Do not exceed corrosion limits.** The Uniseal is designed to resist corrosion through proper material selection. Do not expose the Uniseal materials of construction to products outside of their corrosion limits. Consult Flowserve for chemical resistance recommendations.
- 4.5 **Do not exceed pressure and speed limits** established for the Uniseal.
- 4.6 **Do not exceed the temperature limits** of the Uniseal based on the materials of construction. For dual seals using supply tanks with cooling coils, turn on cooling water to the supply tank before start-up.
- 4.7 **Do not start up or run the Uniseal dry.** The seal chamber, pump and support systems should be thoroughly vented before start-up. Buffer or barrier fluid must flood the seal cavity of dual seals at all times during operation. Process fluid must be in the seal chamber at all times during single seal operation.



TO REORDER REFER TO
B/M # _____
F.O. _____

5 Repairs

This product is a precision sealing device. The design and dimension tolerances are critical to seal performance. Only parts supplied by Flowserve should be used to repair a seal. To order replacement parts, refer to the part code and B/M number. A spare backup seal should be stocked to reduce repair time.

When seals are returned to Flowserve for repair, **decontaminate the seal assembly** and include an order marked "**Repair or Replace.**" **A signed certificate of decontamination must be attached. A Material Safety Data Sheet (MSDS) must be enclosed** for any product that came in contact with the seal. The seal assembly will be inspected and, if repairable, it will be rebuilt, tested, and returned.

FIS213eng ORG 09/11 Printed in USA

**To find your local Flowserve representative
and find out more about Flowserve Corporation,
visit www.flowserve.com**

Flowserve Corporation has established industry leadership in the design and manufacture of its products. When properly selected, this Flowserve product is designed to perform its intended function safely during its useful life. However, the purchaser or user of Flowserve products should be aware that Flowserve products might be used in numerous applications under a wide variety of industrial service conditions. Although Flowserve can provide general guidelines, it cannot provide specific data and warnings for all possible applications. The purchaser/user must therefore assume the ultimate responsibility for the proper sizing and selection, installation, operation, and maintenance of Flowserve products. The purchaser/user should read and understand the Installation Instructions included with the product, and train its employees and contractors in the safe use of Flowserve products in connection with the specific application.

While the information and specifications contained in this literature are believed to be accurate, they are supplied for informative purposes only and should not be considered certified or as a guarantee of satisfactory results by reliance thereon. Nothing contained herein is to be construed as a warranty or guarantee, express or implied, regarding any matter with respect to this product. Because Flowserve is continually improving and upgrading its product design, the specifications, dimensions and information contained herein are subject to change without notice. Should any question arise concerning these provisions, the purchaser/user should contact Flowserve Corporation at any one of its worldwide operations or offices.

© Flowserve Corporation (2011)

USA and Canada

Kalamazoo, Michigan USA
Telephone: 1 269 381 2650
Telefax: 1 269 382 8726

Europe, Middle East, Africa

Roosendaal, the Netherlands
Telephone: 31 165 581400
Telefax: 31 165 554590

Asia Pacific

Singapore
Telephone: 65 6544 6800
Telefax: 65 6214 0541

Latin America

Mexico City
Telephone: 52 55 5567 7170
Telefax: 52 55 5567 4224