



Fire Protection Pumps



Experience In Motion



Pump Supplier to the World

Flowserve is the driving force in the global industrial pump marketplace. No other pump company in the world has the depth or breadth of expertise in the successful application of pre-engineered, engineered, and special purpose pumps and systems.

The Trusted Partner for Complete Fire Protection Pump Systems

For more than 30 years, Flowserve has supplied fire protection pumps and systems in compliance with French, European and international standards. Various configurations of Flowserve pumps are designed to provide water to stand pipe, sprinkler, foam mitigation, and hydrant systems for fire protection in industrial and commercial facilities as well as refineries and offshore platforms.



Product Brands of Distinction

ACEC™ Centrifugal Pumps

Aldrich™ Pumps

Byron Jackson® Pumps

Calder™ Energy Recovery Devices

Cameron™ Pumps

Durco® Process Pumps

Flowserve® Pumps

IDP® Pumps

Lawrence Pumps®

Niigata Worthington™ Pumps

Pacific® Pumps

Pleuger® Pumps

Scienco™ Pumps

Sier-Bath® Rotary Pumps

TKL™ Pumps

United Centrifugal® Pumps

Western Land Roller™ Irrigation Pumps

Wilson-Snyder® Pumps

Worthington® Pumps

Worthington Simpson™ Pumps



Recognized International Standards

FlowsERVE offers a broad selection of proven, reliable pumps for fire protection services, ranging from commercial applications to the most demanding oil and gas, hydrocarbon processing, chemical plant and power generation services.

Pumps are designed in accordance with APSAD R1, NFPA20, NFEN 12845, CEPREVEN-UNE, API, ISO, ANSI, HI and other recognized international standards as well as FlowsERVE standards and customer specifications.

Designs include:

- Axially split, one- and two-stage between bearings pumps for high- and low-pressure services
- Radially split multistage pumps for high-pressure service
- Compactly designed vertical in-line pumps for lower flow ranges
- Frame mounted and close coupled end suction design pumps for low and medium pressure services
- Vertical turbine pumps for high-capacity service and when operating under static suction lift conditions

Committed to the Complete Pump System Life Cycle

For more than two centuries, FlowsERVE has served industries requiring solutions that add value and reduce costs throughout the life cycle of a pumping system.

- Water
- Oil and gas
- Power generation
- Chemical
- General industry

FlowsERVE partners with customers to respond to the dynamic business conditions that affect them. FlowsERVE works with customers to improve efficiency, maximize throughput and control process quality. Whether customer needs involve on-site technical assistance, equipment upgrades or broader project planning with full turnkey responsibility, FlowsERVE delivers professional, reliable results.





Complete Systems Reliability

Globally recognized for quality and reliability, Flowserve offers pump, equipment and systems for virtually all fire suppression applications. All components meet or exceed applicable standards. Control panels comply with APSAD, NFEN, NFPA, CEPREVEN-UNE or FM standards, as required by customer specifications.

Standard Product Offerings

- **Jockey and Source A (APSAD)** – Compact electrical packaged skids include one or two close coupled pumps, all electrical panels, pressure switches and over pressure tank.
- **Source B Electrical Units (APSAD)** – Baseplate mounted, main pump available with an electric motor, semi-flexible transmission and control panels.
- **Diesel Units** – Compact pump packages include diesel motor with universal joint (Cardan shaft), control panels and cooling system (heat exchanger or radiator). Units are performance tested prior to shipment.
- **RIA (Fire Hose Reels)** – Packaged units include two close coupled pumps, collectors, valves, pressure switches and start-up control panel.
- **Foam Mitigation Systems** – Units are designed for low and medium viscosity applications. Packages include pump and electrical motor or diesel engine.





Performance Testing

FlowsERVE provides certified performance curves for all its fire suppression pumps. All units are hydrostatically and electrically tested at the factory for performance to specification. FlowsERVE test facilities include:

- Multiple test loops with flows to 25 000 m³/h (5680 gpm)
- Electrical power testing to 4.6 MW (6168 hp)
- Test pits for vertical pumps
- Dedicated stands for engine tests

Available Accessories

- Electric motor controller accessories
- Diesel engine controller accessories
- Ventilation systems
- Noise reduction systems
- Pneumatic and hydraulic motor starters
- Fuel tank configurations
- CO₂ fire suppression
- Low NOx emission

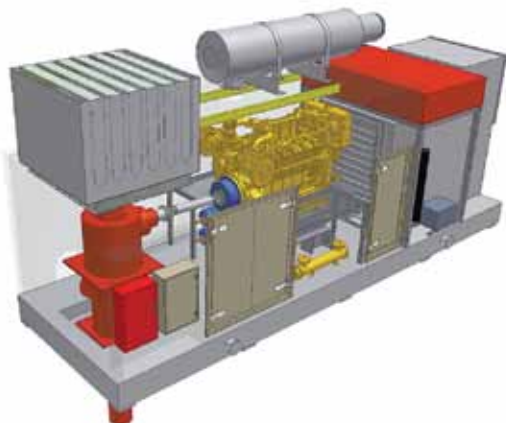

Custom-Engineered Systems

Custom-engineered and self-contained fire protection pump systems are available as either skid-mounted packages or as fully containerized units. These pre-packaged configurations include pumps, drives, controls, headers, pipes, fittings and electrical wiring to meet or exceed all applicable codes. An electrical test verifies component integrity. On-site installation only requires piping and electrical connection.

A selection of electric, diesel or dual-drive configurations is available from recognized suppliers to best meet installation and reliability requirements or customer preference. Pump materials are available to handle fresh water, brackish or seawater applications.

Design Services and Upgrades

FlowsERVE applications engineers possess the systems and specifications knowledge along with real world experience to develop safe, reliable systems and system upgrades to meet client needs.

- Start-up and commissioning (Field Service National, International)
- On-site maintenance and repair
- Pump and installation upgrades
- Hydraulic and electrical assessments
- Training



Broad Application Coverage

- Jockey and Source A
- Source B Electrical Units
- Diesel Units
- RIA
- Foam Mitigation

● ● ● ● ● ○ **Single-Stage, End Suction Pumps**
(MEN and MENBLOC)

Frame mounted (MEN) or close coupled (MENBLOC) pumps compliant with DIN 24255 and EN 733

Operating Parameters

- Flows to 800 m³/h (3520 gpm)
- Heads to 140 m (450 ft)
- Pressures to 16 bar (230 psi)

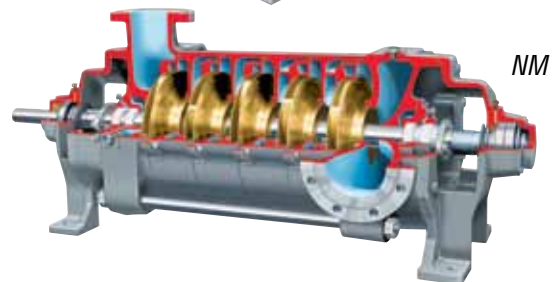
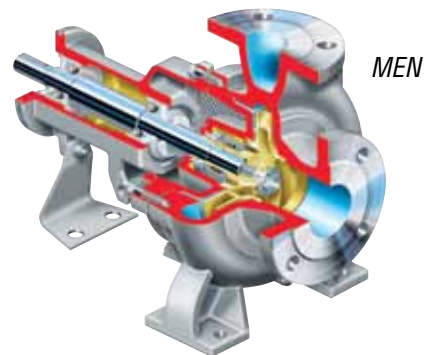

● ● ● ○ ○ **Horizontal Multistage Pumps**
(FP and NM)

Between bearings and overhung designs available in numerous horizontal and vertical configurations

Operating Parameters

- Flows to 500 m³/h (2200 gpm)
- Heads to 250 m (820 ft)
- Pressures to 25 bar (365 psi)

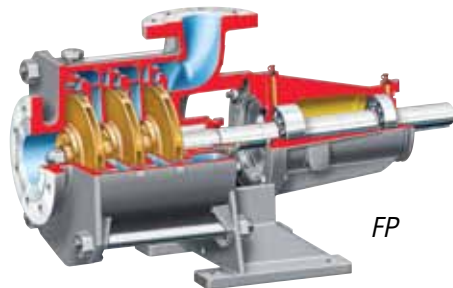

● ● ● ● ● **ASME and ISO Process Pumps**
(Durco Mark 3™ and CPX)

Compliant with ASME B73.1 (Durco Mark 3) or ISO 2858 and 5199 (Durco Mark 3 ISO); self-priming, in-line and close-coupled configurations available

Operating Parameters

- Flows to 1680 m³/h (7400 gpm)
- Heads to 220 m (720 ft)
- Pressures to 27 bar (400 psi)

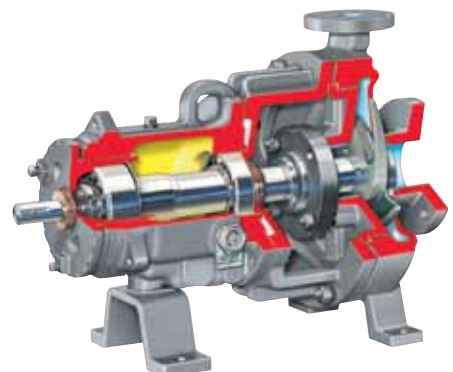

Durco Mark 3



● ● ○ ○ ○ **Vertical Submersible Motor Pumps**
(Pleuger SUBM)

Multistage, vertical pumps featuring wet type motors with watertight insulated windings

Operating Parameters

- Flows to 3000 m³/h (13 210 gpm)
- Heads to 500 m (1640 ft)
- Pressures to 60 bar (870 psi)

● ● ● ○ ○ **Vertical Turbine Wet Pit Pumps**
(VTP)

Single or multistage designs with enclosed or semi-open impellers; numerous drive options available

Operating Parameters

- Flows to 13 600 m³/h (60 000 gpm)
- Heads to 700 m (2300 ft)
- Pressures to 100 bar (1450 psi)

● ● ● ○ ○ **Axially Split Pumps**
(LR, LLR and LNN)

Double-suction, between bearings designs with ANSI, DIN or ISO flanges. Vertical, bottom-suction and two-stage configurations available

Operating Parameters

- Flows to 30 000 m³/h (132 000 gpm)
- Heads to 300 m (980 ft)
- Pressures to 40 bar (580 psi)

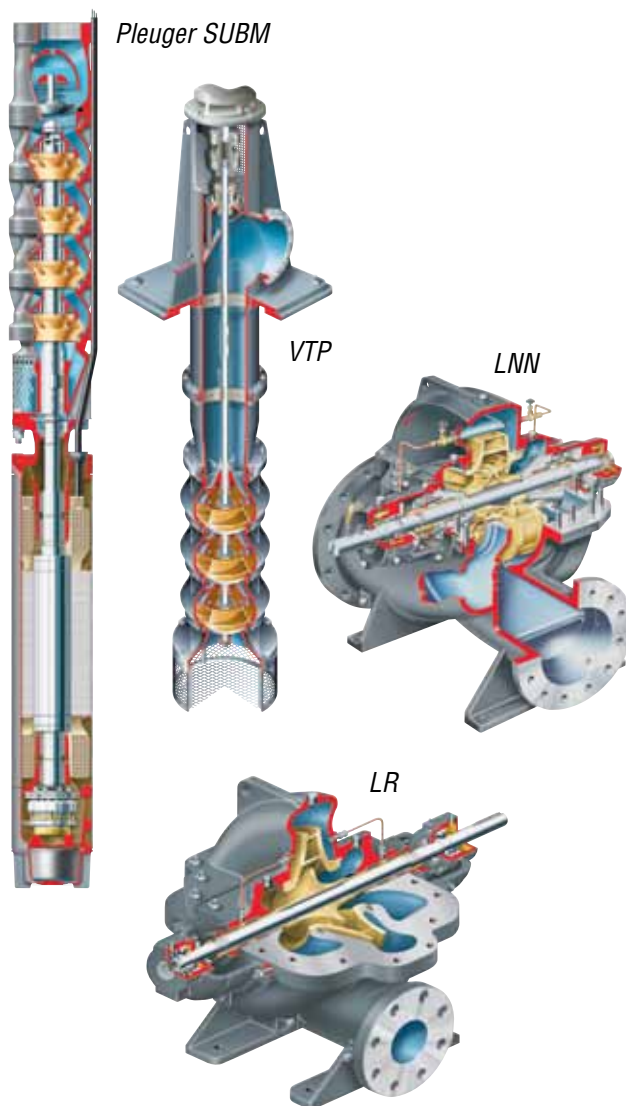

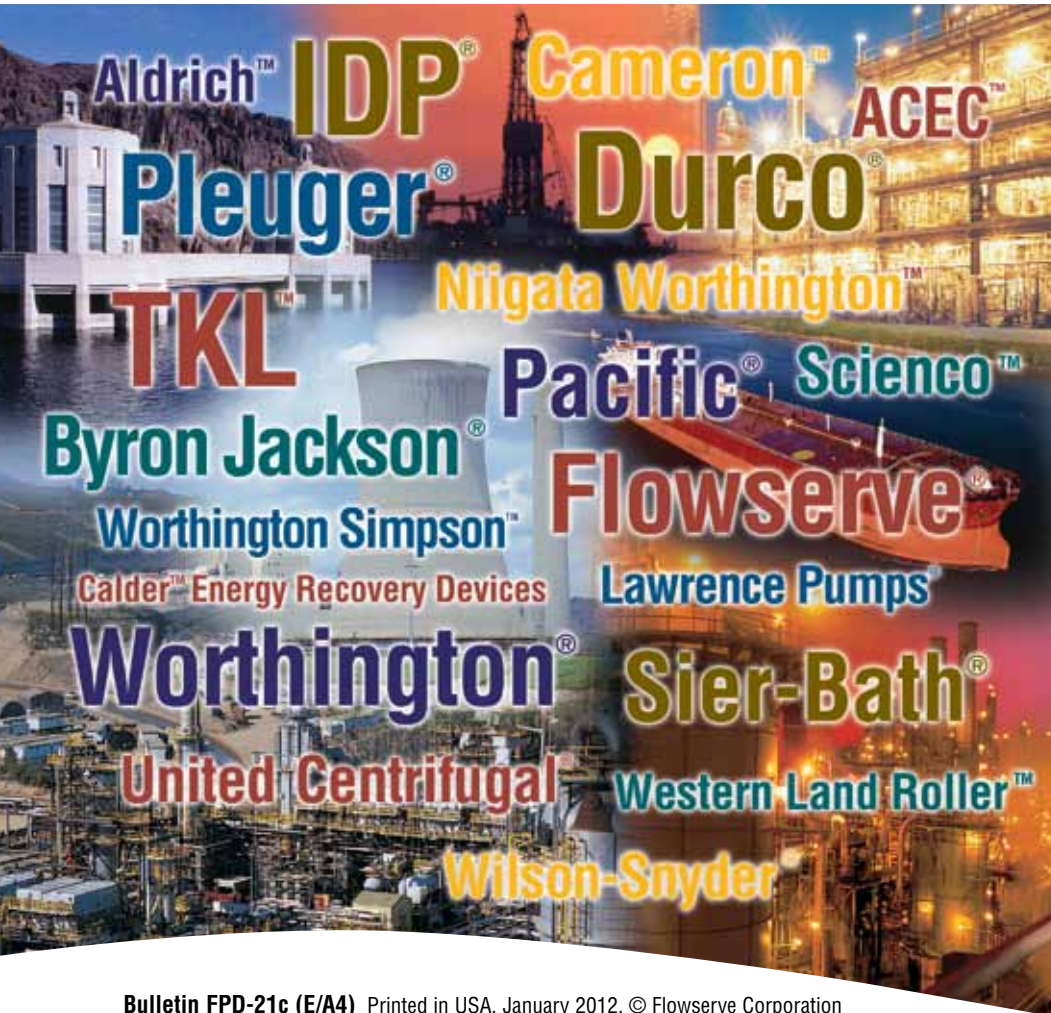

Bulletin FPD-21c (E/A4) Printed in USA. January 2012. © Flowserve Corporation

To find your local Flowserve representative:

For more information about Flowserve Corporation,
visit www.flowserve.com or call +1 937 890 5839.

USA and Canada

Flowserve Corporation
5215 North O'Connor Blvd.
Suite 2300
Irving, Texas 75039-5421 USA
Telephone: +1 937 890 5839

Europe, Middle East, Africa

Flowserve Corporation
Parallelweg 13
4878 AH Etten-Leur
The Netherlands
Telephone: +31 76 502 8100

Latin America

Flowserve Corporation
Martín Rodríguez 4460
B1644CGN-Victoria-San Fernando
Buenos Aires, Argentina
Telephone: +54 11 4006 8700
Telefax: +54 11 4714 1610

Asia Pacific

Flowserve Pte. Ltd.
10 Tuas Loop
Singapore 637345
Telephone: +65 6771 0600
Telefax: +65 6862 2329