



# ***Worcester Controls CPT Characterized Seat Control Valve***

Customized Control for Severe Throttling Services



*Experience In Motion*



## ***Flowserve Worcester CPT Characterized Seat Control Valves***

After years of research and performance evaluation under severe throttling services, where precise computer control was required, Flowserve Worcester Controls has developed the CPT characterized seat control valve series. These valves exceed the performance features of traditional linear valves, as well as that of segmented ball and eccentric plug designs.

The CPT characterized seat control valve is a ball valve, but that's where the similarity ends. The control capacity is defined by a revolutionary seat technology. These seats consist of a sintered stainless steel material that has been fully impregnated with TFE or Graphite, then laser-cut to a customized shape to best suit the individual application.

Combine these capabilities with Flowserve's high-cycle pneumatic, electric, or electro-pneumatic actuators, positioners, and accessories, and you have a control valve package that will meet the performance capabilities available with computers and PLC controllers.



- Precision control
- Zero external leakage
- High cycle capability
- Interchangeable characterized seats
- High rangeability (turn down)
- Efficient shearing action for solids and fibers
- Tight shutoff—bubbletight
- Low maintenance, few parts
- Compact design, light weight
- High flow capacity
- Energy efficient



## Advanced Control Technology

Look beyond traditional globe control valves to a valve technology that gives you high pressure drop capability with straight-through flow, precision control, shearing action, erosion control and bubbletight shutoff. This technology is the CPT's self-lubricated, full contact seat of sintered stainless steel impregnated with TFE or graphite. The flow characteristic is laser cut to a "V" shape, slots, or customized shapes to meet any control requirement. The V-shaped port is available in seven standard angles for equal-percent characteristic with capacity closely matched to system needs. The lubricating action of the special coating on the ball and TFE or graphite impregnation throughout the thickness of the characterized seat results in amazingly smooth, stable throttling control.

The characterized seat design allows use of exotic materials such as Inconel 600®, Hastelloy C22®, Stellite 6 or Monel®.

### FM Oil and Gas Safety Shutoff

The ¼"-2" CPT 44 series valves and ½"-4" CPT 51/52 valves with Pulsair III are approved by Factory Mutual for oil and gas safety shutoff service and flow control. For further information, contact the Custom Products Department.

### Standard ΔP Capabilities

Liquids to 500 psi

Steam to 300 psi



**316 sintered metal seats are impregnated with TFE or graphite to provide positive shutoff and lubrication when contacting the hard coated ball.**

**Characterized Seats with Metal A (TFE impregnation) or Metal G (graphite impregnation) are available in sizes ¼"-4".**



## A High Pressure Drop Control Valve with Custom Characteristics and Bubbletight Shutoff

The characterized seat control valve gives you extremely accurate control through the entire valve stroke with seat openings designed specifically for your process. This design means efficient, straight-through flow, rotary shaft sealing and bubbletight shutoff.

The seat design makes a throttling control valve that is both forgiving and accommodating. If a valve is sized incorrectly or if process conditions change, you can change the Cv and/or the control characteristic by merely changing out the seat.

At last! A control valve that shuts off bubbletight. The floating ball concept and Worcester Controls proprietary metal CPT seat design allows the valve to be bi-directional and still exceed ASME Class VI shutoff. The unique design of the Worcester CPT utilizes both a 316 stainless steel metal seat and a resilient seat, allowing for less operating torque than traditional ball control valves.



- Characterized seat
- Resilient or round metal seat

The characterized seat control valve is a bi-directional valve.

Flowserve recommends that the CPT seat be located in the downstream position in applications where the potential for erosion exists so any potential damage will occur away from the valve body. This is a major improvement in applications where damage by erosion in the valve body has been an expensive and time consuming problem.

## Control Valve Sizing Software

Flowserve Performance! Software is now available to support your applications and project activities. Order your copy of Performance! today! For more information, or to download a trial version, go to <http://performance.flowserve.com>.

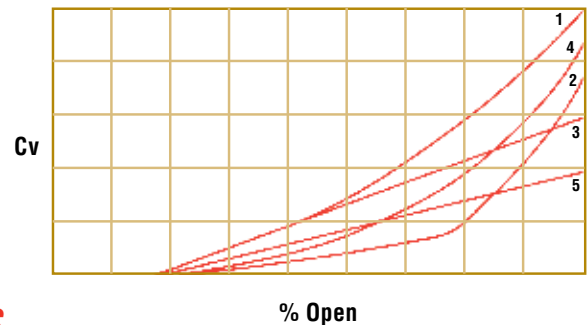

## Virtually Limitless Seat Designs

The V-shape of the standard seat (1) in CPT characterized seat control valves is precision laser cut and offers inherent modified equal percentage flow characteristic. Slotted seat valves (3) have inherent linear flow characteristics. If your requirements are different, we change the seat cut. Seats with multiple ports and custom openings (2, 4, and 5) are available to meet your unique control needs.

Simple changeout of the seat permits change of valve characteristic to match your process requirements.

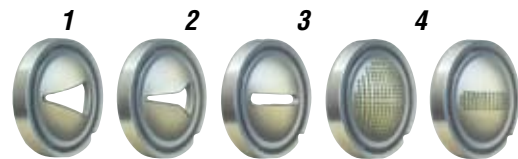

## Vee-Twin Valves for the Most Severe Applications

Flowserve offers the CPT Vee-Twin for more severe applications. The Vee-Twin design combines two CPT seats into one body for staged pressure reduction. This results in better resistance to cavitation and reduced noise.

In addition to providing excellent resistance to cavitation, the dual Characterized V-port seats are not subject to fouling like conventional anticavitation trims that utilize many small holes. The Vee-Twin allows relatively large particles to pass through the valve, and the shearing action of the ball against the seat slices off fibrous contaminants and cleans the seating surface in every cycle.

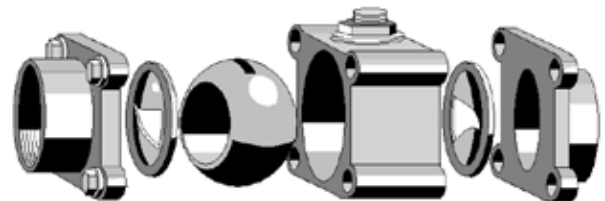

Seat leakage is less than allowed by ANSI Class IV. The Vee-Twin option is available on all versions of the CPT, but special actuator sizing applies. Refer to page 22 for actuator sizing data and for flow coefficients, refer to page 20.

## Complete Piping Versatility

### One Control Valve, Six Valve Configurations, Hundreds of Characteristics

The CPT control valve is not locked into one body style. Now you can choose a characterized seat control valve for the compactness of skid-mounted systems, the ruggedness of flanged piping, the high pressure integrity of welded systems, and the leakproof containment of sterile fluids\*, cryogenics\*, and chemicals in the EPA's Toxic Release Inventory.



**Valve Configuration**

Cryogenic design,  
Three-piece (shown) or flanged

**Model**

C44, C51/C52

**Sizes**

1/4", 1/2", 3/4", 1", 1/2", 2", 3", 4"

**Pressure Rating**

1000 psi max.

**End Connections**

Screw end, socket weld, butt weld,  
ASME Class 150 or 300 flanges



**Valve Configuration**

Wafer

**Model**

CPT 151, CPT 301

**Sizes**

3", 4"

**Pressure Rating**

ASME Class 150, ASME Class 300

**End Connections**

Wafer – for use between ASME  
Class 150 or Class 300 flanges



**Valve Configuration**

Flanged

**Model**

CPT 51, CPT 52

**Sizes**

1/2", 3/4", 1", 1 1/2", 2", 3", 4"

**Pressure Rating**

ASME Class 150, ASME Class 300

**End Connections**

ASME Class 150 or Class 300  
raised face flanges



**Valve Configuration**

Three-piece

**Model**

CPT 44

**Sizes**

1/4", 1/2", 3/4", 1", 1 1/2", 2"

**Pressure Rating**

1000 psi max.

**End Connections**

Screw end, socket weld, butt weld



**Valve Configuration**

Anti-fugitive emission three-piece

**Model**

CPT 94

**Sizes**

1/4", 1/2", 3/4", 1", 1 1/2", 2"

**Pressure Rating**

1000 psi max.

**End Connections**

Screw end, socket weld, butt weld



**Valve Configuration**

Anti-fugitive emission flanged

**Model**

CPT 94

**Sizes**

1/2", 3/4", 1", 1 1/2", 2", 3", 4"

**Pressure Rating**

ASME Class 150, 300, 600

**End Connections**

Raised face flanges

\* Characterized seat clean valves and cryogenic valves are available through Flowserve's Custom Products Department.

## Advanced Stem Design for Low Hysteresis, High Repeatability and Leak-Free, Stick-Free, High-Cycle Operation

Flowserve Worcester Controls CPT characterized seat control valves represent a profound improvement over traditional globe and rotary valves that use heavy linear actuators, crank arms, and associated linkage. Worcester Controls has eliminated significant hysteresis and assured repeatability by powering through a solidly clamped, in-line stem. All shafts operate together: actuator, positioner, valve stem. The design also eliminates side load on the valve stem because components (valve, actuator, positioner) are mounted symmetrically and forces are balanced. This extends valve seal life far beyond conventional valves.

### High-Performance Stem Seals

A new stem seal design, consisting of PEEK and Polyfill® thrust bearings and seals, significantly increases valve cycle life over conventional control valves and extends time between adjustments. The stem seal is live loaded to compensate for wear or thermal effects. Valve action is rotary. This means that toxic fluids, flammable fluids, and fluids that tend to crystallize or oxidize upon contact with atmosphere are fully contained and do not inhibit the freedom of motion of the valve.

### Stem Seals for EPA Requirements

For an extended leak-free process environment, extended temperature application, and to meet EPA requirements, Worcester Controls offers the CPT 94 Control Valve. The Series CPT 94 valve is a NACE compatible, rugged, throttling ball control valve for fluids such as chlorine, phosgene, and many toxic liquids and gases. All Worcester Controls standard and characterized seats are available in this valve configuration. The heart of the Series 94 valve is a large diameter stem with double, live-loaded seal, and a Lantern-Ring connection. The connection may be used to detect and channel unlikely leakage from the primary seal, or may be used to create a liquid/gas seal for the stem, or for a steam purge to provide a sterile packing. A second connection is optional. Seal loading is kept constant with a series of Belleville washers. The standard seal consists of a TFE box ring with TFE V-ring packing. Graphite packing is optional.

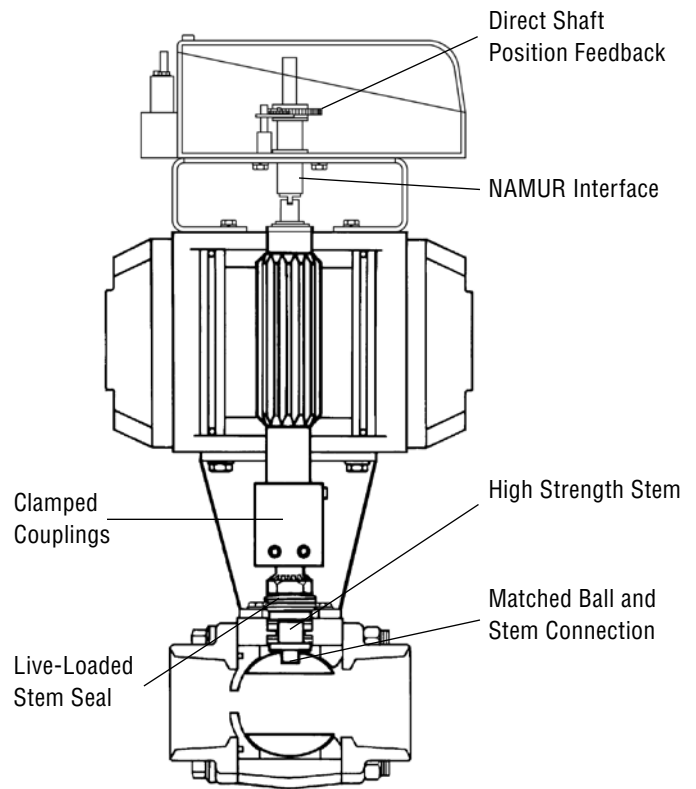

Standard high-cycle, live-loaded, high-performance stem seal

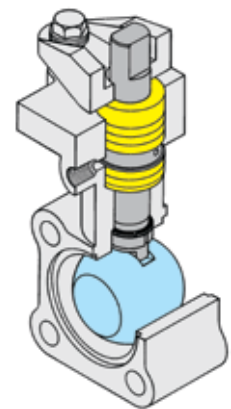

Series CPT 94 high-cycle, anti-fugitive emission stem seal

## Applications

### Steam Control

Controlling steam pressure is not easy. Typical problems associated with globe control valves in steam service have been stem leakage, sticking, poor shutoff, and high maintenance. Linear stem valves require frequent packing adjustment and over-tight packing may create added stem friction that could cause controller instability. Furthermore, Class V, IV, or III shutoff is usually too much leakage for many applications requiring tight shutoff.

Worcester Controls characterized seat valves solve these problems with tight shutoff exceeding Class VI. Self-compensating rotary stem seals and tailored seat characteristics provide a ramp-up condition quickly while maintaining precision low-flow control. Thousands of CPT valves are successfully operating in steam systems where globe valves were originally used. A typical user reaction: "We are removing our globe valves and replacing them with Worcester Controls characterized seat control valves because they work better and control better."

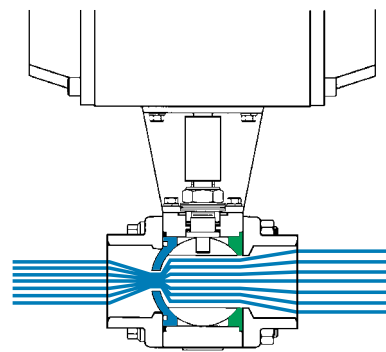

### Toxic Fluids

Traditional rising stem globe valves cannot stand up to the demanding specifications implemented by the EPA, OSHA and other regulating agencies. The very nature of the design, even with double packing and/or bellows seals have relatively short cycle lives compared to rotary seals. The



Series CPT 94 control valve shown on page 6 has been certified by third party testing, allowing less than 25 ppm leakage, whereas EPA requirements are 500 ppm. Self-adjusting stem seals with multiple Belleville washers make this valve ideal for throttling toxic chemicals.

### pH Control

Low flow rates associated with pH process control loops require valves with very small openings. This creates a major problem in traditional rising stem control valves if any solids larger than the valve opening are in the system. Unfortunately, in most pH systems, it is impossible to eliminate solids in the liquid stream. They often clog control valves. This results in having to shut the line down and disassemble the valve for cleaning.

The CPT is the ideal control valve for pH control when using a low flow opening and solid removal hole. The special opening of the pH control seats, shown, provide the most ideal throttling characteristics and turndown while allowing solids to move out of the larger opening. Also, erosion problems are minimized and the valve body is protected since the vena contracta is located outside the valve body.

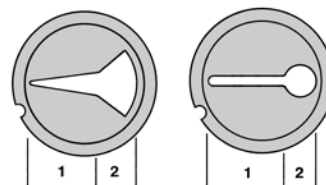

## Applications

### Cryogenics

Compactness, balanced weight, precision control, tight shutoff, and long service life are features considered unique and unmatched by conventional control valve designs and styles. The cryogenic characterized seat valve is also designed to handle large temperature swings with its special seats and self-compensating rotary stem seal design. All this has made CPT an ideal control valve for low temperature and cryogenic applications such as freezing systems, lyophilization systems, high-purity gas systems, terminal loading stations, over-the-road CO<sub>2</sub>, LNG food carriers, and air separation systems. The characterized valve provides tailored flow characteristics for each process—in the body and trim materials you require. CPT valves can be easily and economically controlled by Worcester Controls Series 39 pneumatic or Series 75 electric actuators.



### Series 39 Actuator

The heart of our pneumatic automation package is the Series 39 actuator. A Worcester Controls innovation, the Series 39 is an accurate, compact, powerful, double-piston, rack-and-pinion actuator with an impressive track record for reliability. That's why we back it with an exclusive two-year warranty. One plant reported 14 million complete cycles without appreciable original seal wear.

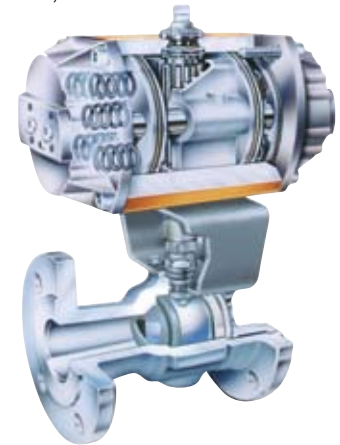

Piston tilting is prevented due to unique guide rods that always keep the pistons parallel with each other and perpendicular to the cylinder. This feature enables the Series 39 actuator to match the performance of diaphragm actuators in terms of high resolution. Internal friction is reduced with a nickel acetate-coated cylinder, low coefficient-of-friction acetal resin bearings and a special permanent lubricant with corrosion inhibitors.

Worcester's control valve packages are designed to function with virtually no inherent hysteresis, an important feature in throttling control. Precision parts within the Series 39 actuator permit very high torque performance with minimum backlash.

### Series 75 Actuator

Presenting the ultimate actuator package for electronic process control: the Series 75. Ideal for analog or digital controlled systems where pneumatic control is neither possible nor desirable.

The Series 75 actuator adds a new dimension of operational dependability and flexibility to modern processes controlled by computers and programmable logic controllers. It is compact and powerful. Its brushless, split phase capacitor, start/run reversing AC motor or rugged and powerful DC motor, drives the valve through a permanently lubricated gear train which offers virtually lifetime maintenance-free, dependable operation. Precision throttling control is achieved by a choice of electronic positioners and controllers that can work with digital or analog control loops. A variety of options allow you to select the performance criteria, diagnostic data and feedback information you desire.



## New Technology – Positioners and Accessories



Now is your opportunity to stop oscillation or hunting in your process. Most process control loops are unstable due to an improper valve characteristic, positioner characteristic or both. The Worcester Controls CPT characterized seat control valve with either the Pulsair III or DataFlo positioner puts a permanent stop to these problems. It is done by tailoring the characterized seat opening and free character-

istic curve of the positioner for each process loop. Install our control valve package in any of your flow, temperature, pressure, vacuum or other demanding or critical control applications and find out how our new technology can give you the precise control you have always looked for but couldn't achieve with traditional control valves and positioners.

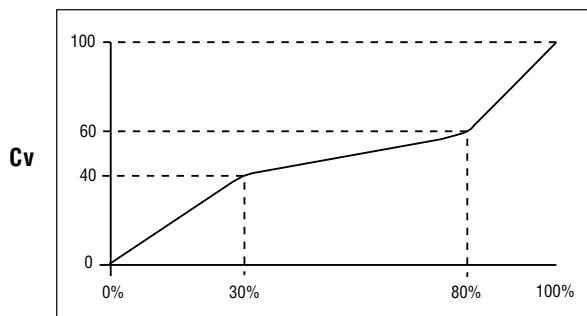

20% Cv change for 50% valve rotation is a tailored CPT valve characteristic. Result is 0.1°F control of temperature or 0.1 psi pressure control.

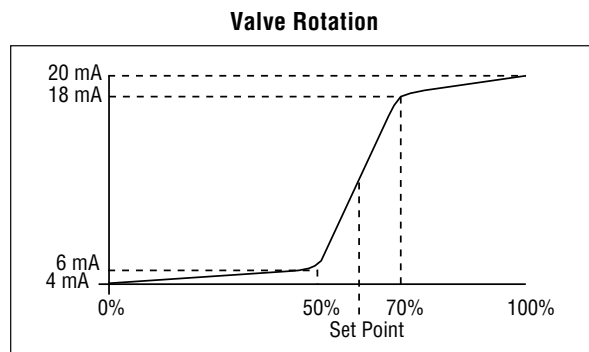

Above free tailored characteristic programmed in Pulsair III or DataFlo uses 75% of the available signal to move the valve around the set point position by only 20%.

**Flowserve offers all the accessories you need for precise control valve positioning and position feedback.**

### For pneumatically actuated control valves

The Pulsair III loop-powered valve positioner with auto calibration and zero air bleed is a totally new concept in pneumatic control valve positioning. Operated and controlled by a 4–20 mA analog signal, Pulsair III is microprocessor-based with piezoelectric valves. Air is pulsed to the actuator pistons, eliminating constant air bleed and providing very accurate positioning without overshoot. With a 100-plus-function menu and a five-button keypad, you can automatically calibrate the positioner, change valve action, split range, modify the control characteristic and select many other control parameters. Intrinsically safe option available. Ask for brochure FCD WCABR1019.



Through-cover display  
XP enclosure

### For electrically actuated control valves

The DataFlo P™ Positioner, controlled by a 4–20 mA analog signal from a PLC or digitally from a computer, gives you calibration, monitoring and diagnostics both on-site or from a control room computer. This dramatically increases system dependability and lowers valve calibration, monitoring, and maintenance costs.



### An electronic positioner with a built-in microcontroller for precise process control

DataFlo P controls your process better and turns your final control element into an efficient digital communications platform. Standard PM15 positioners are offered for 3–15 psi pneumatic control and AF17 positioners for analog control of electrically actuated control valves. Refer to brochures FCD WCABR1032 and FCD WCABR1000.



Three-button keypad for on-site  
calibration and functional setup

## New Technology – Direct Process Control

The DataFlo C™ controller is a fresh approach to PID control. This combination microcontroller-based PID single-loop controller and final control element brings control to the point of use. The rugged compact package simplifies wiring requirements by directly accepting RTD, analog or thermocouple inputs. The signal does not have to be conditioned, improving reliability. All the parameters are easily programmable through the local keypad or via a simple RS-485 computer interface. The control valve/PID controller is easily tuned to the loop with the built-in auto tune program (excluding level control). Refer to brochure FCD WCABR1021.

### PC/PLC/Computer Interface and Manual Valve Control

Remote interface capability allows the user to monitor their process and change the controller settings. An additional feature allows the user to take the controller off-line and operate in a manual positioning mode. The user can switch

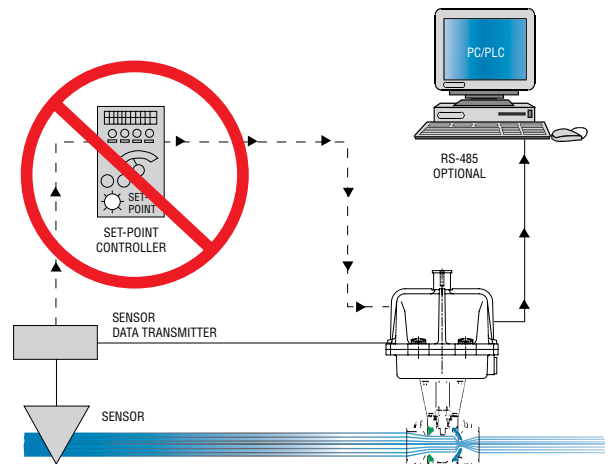

between PID control and a linear positioning mode by a discrete 24 VDC output from the PLC. An operator can also change set point input via an analog input to the controller.

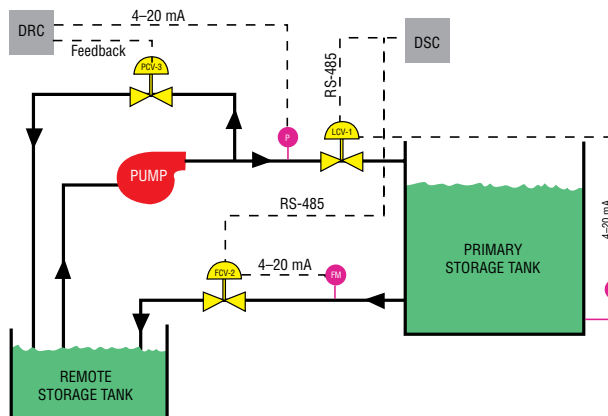

### DRC/DSC

Flowserve introduces two new products that allow the customer the capability to control and monitor their process control valves from a remote location.

The DataFlo Remote Controller (DRC) is specifically designed to interface with electrically actuated control valves. This combined positioner-controller accommodates multiple I/O options for both set point and process inputs. Performance monitoring and maintenance diagnostic data is available locally for “real time” user interface and remotely for predictive maintenance programs. The DRC is packaged in a NEMA 4X enclosure and features a splash-proof keypad and bright alphanumeric LED display for user-friendly interface.

The DataFlo Supervisory Controller (DSC) is designed to interface with multiple process control valves via a two-wire fieldbus network. The DSC provides interface process control and performance monitoring for a maximum of 31 process control loops. (Performance monitoring and maintenance diagnostic data is available locally for “real time” user interface and remotely for predictive maintenance programs.) The DSC is packaged in a NEMA 4X enclosure and features a 16-key splash-proof keypad and four-line “avionics” grade LED display for user-friendly interface. The DSC is a cost effective solution that eliminates expensive traditional “PLC” type systems with central control and point-to-point wiring.

### Process Control Solutions

- LCV-1: Level control – differential pressure  
DataFlo supervisory controller (process interface)
- FCV-2: Flow control (tank discharge) – flow meter  
DataFlo supervisory controller (process interface)
- PCV-3: Pressure control (pump bypass) – pressure transducer  
DataFlo remote controller (process interface)



## Specifications

### Characterized Seat Control Valves

#### CPT 51/52 Flanged Control Valves

**Valve Size:** ½", ¾", 1", 1½", 2", 3", 4"

**Valve Pressure Class:**

CPT 51 – ASME Class 150 flanges  
CPT 52 – ASME Class 300 flanges

**Body and End Plug Materials:**

Carbon steel, 316 stainless steel  
Other materials available upon request.

**Stem Seal Assembly:**

PEEK and Polyfill (½"–2")  
Refer to Series 51/52 brochure.

**Maximum Valve Temperature:** 650°F

For higher temperatures consult Flowserve.

#### C44, C51/C52 Cryogenic Control Valves

**Valve Size:** ¼", ½", ¾", 1", 1½", 2" (three-piece valves) 1"–4" flanged valves

**Valve Pressure Class:**

ASME Class 600 (This is the body pressure rating.)  
Seat selection may derate the valve.

**Body and Pipe End Materials:**

Carbon steel, 316 stainless steel  
Other materials available upon request.

**End Connections:**

Screw end, socket weld, butt weld

**Stem Seal Assembly:**

PEEK and Polyfill — Refer to Series 44 brochure.

**Maximum Valve Temperature:** 600°F

For higher temperatures consult Flowserve.

#### CPT 44 Three-Piece Control Valves

**Valve Size:** ¼", ½", ¾", 1", 1½", 2"

**Valve Pressure Class:**

ASME Class 600 (This is the body pressure rating.)  
Seat selection may derate the valve.

**Body and Pipe End Materials:**

Carbon steel, 316 stainless steel  
Other materials available upon request.

**End Connections:**

Screw end, socket weld, butt weld

**Stem Seal Assembly:**

PEEK and Polyfill — Refer to Series 44 brochure.

**Maximum Valve Temperature:** 650°F

For higher temperatures consult Flowserve.

#### CPT 151/301 Wafer Control Valves

**Valve Size:** 3" and 4"

**Valve Pressure Ratings:** To ASME Class 150 and 300

**Body and End Plug Materials:**

Carbon steel, 316 stainless steel

**Stem Assembly:**

PEEK and Polyfill — Refer to Wafer Ball Valve brochure.

**Maximum Valve Temperature:** 650°F

For higher temperatures consult Flowserve.

#### CPT 94 Three-Piece and Flanged Control Valves

**Valve Size:** ¼", ½", ¾", 1", 1½", 2" – three-piece valves  
½", ¾", 1", 1½", 2", 3", 4" – flanged valves

**Valve Pressure Class:**

ASME Class 600 – three-piece valves  
ASME Class 150 and 300 – flanged valves

**Body and Pipe End or End Plug Materials:**

Carbon steel, 316 stainless steel

**Stem Assembly:**

Dual stem seal of TFE and/or Grafoil, 35% carbon-filled  
TFE or Grafoil — Refer to Series 94 brochure.

**Maximum Valve Temperature:**

600°F with Metal "A" characterized seat  
800°F with Metal "G" characterized seat

### Series 44, 4, 51/52, 151/301 Pressure/Temperature Ratings\*

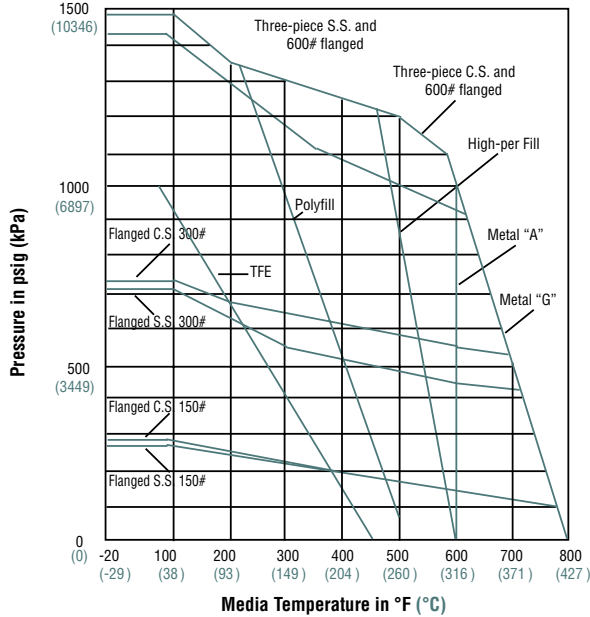

\* For applications above 650°F, use Series CPT 94 valve.

### Series CPT 94 Pressure / Temperature Rating

NOTES: Body seals have pressure/temperature ratings that equal or exceed the rating of the seat. TFE body seals will not withstand thermal cycles in excess of 200°F.

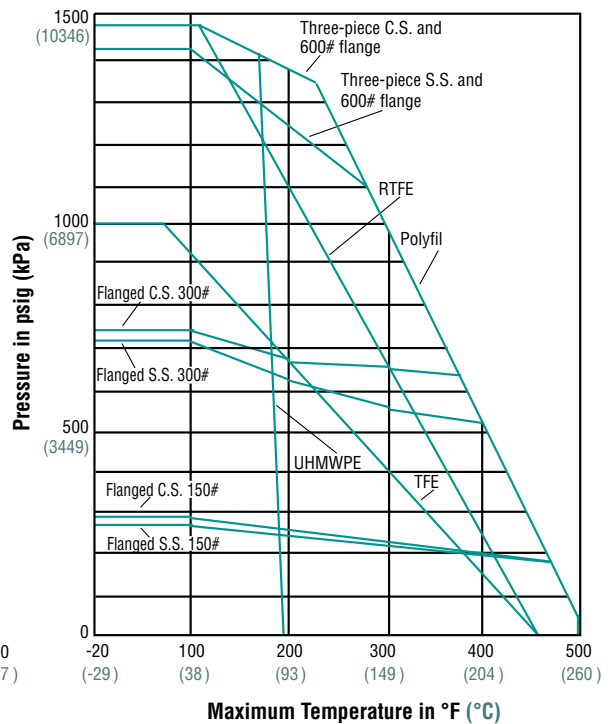
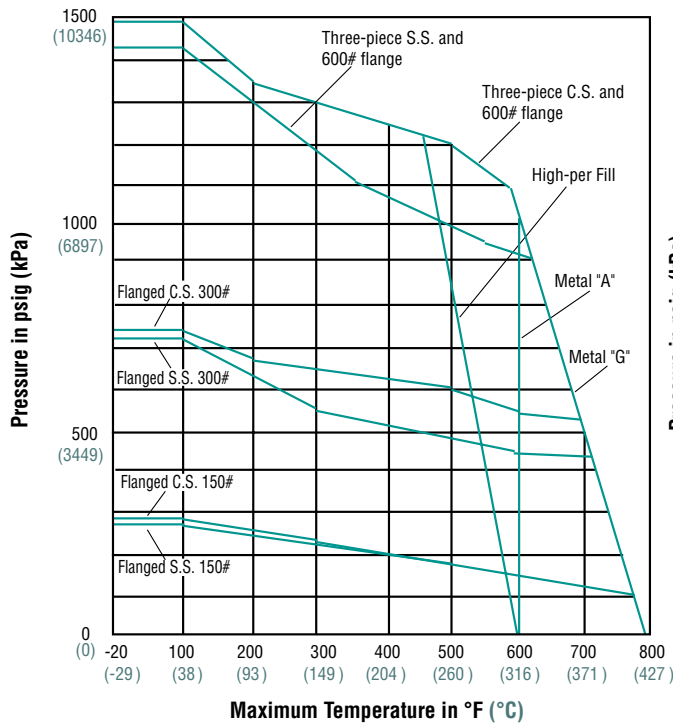

### Actuator Mounting Kits for ¼" – 4" CPT Control Valves

Valve	Actuator Series							
Series	Size	1039 10-1275	15-2072 15-2039 20-2275	2375	2539	3039 25-3075	33-3539	4039
CPT 44	¼" & ½"	MK501S SSMK501S	MK506S SSMK506S	—	—	—	—	—
S 44	¾"	MK502S SSMK502S	MK507S SSMK507S	—	—	—	—	—
S 51 - S 52	1"	MK503S SSMK503S	MK508S SSMK508S	—	—	—	—	—
CPT 51/52	1½" – 2"	MK505S SSMK515S	MK510S SSMK520S	MK515S SSMK525S	MK520S	MK525S	SSMK505S —	SSMK510S —
CPT 51/52	3" – 4"	—	MK248S	MK248S	MK171S	MK119S	MK120S	MK121S
CPT 44 (151/301)	3" – 4"	—	MK248S	MK248S	MK171S	MK375S	MK120S	MK121S

#### Mounting Kit Options

The composition of parts and materials for top-mount mounting kits is different from earlier mounting kits. Therefore, the kits are designated differently. Mounting kits for top-mounted control valves are available in two configurations:

#### Ordering Examples

**MK501S:** Carbon steel polyester coated bracket, on/off zinc coated carbon steel control coupling\* and stainless steel parts including mounting bolts, lockwashers, Belleville washers, and locknut.

**SSMK501S:** All stainless steel parts with control coupling.\*

\*Control couplings are necessary for control valves.

## General Specifications

### CPT Control Valves

**Valve Size:** ¼", ½", ¾", 1", 1½", 2" three-piece valves

#### Characterized Seat:

Metal "A", TFE-impregnated sintered stainless steel Metal "G", graphite-impregnated sintered stainless steel  
Optional materials available, consult Flowserve.

#### Characterized Seat Back Seal:

Graphite; optional Polyfill, silicone  
Encapsulated TFE O-ring or Viton

#### Second Seat (Round):

TFE, Polyfill, High-per Fill, Metal "A", Metal "G"

**Ball:** 316 stainless steel, hard nickel-coated; optional materials available.

#### Valve Orientation and Shutoff:

Characterized seat upstream standard.

Shutoff is bubbletight.

Characterized seat downstream recommended for applications involving cavitation and flashing.

Shutoff exceeds requirements of ASME and ISA Class VI.

#### Standard Pressure Drop Limits:

300 psi – Steam

500 psi – Liquid service

Note: Consult Flowserve for applications about this pressure.

### Recommended Product Specification for Characterized Seat Control Valves

Available with special stem design to meet fugitive emission requirements.

Impregnated Metal Seats – Graphite or TFE-impregnated in 316 stainless steel or other metals.

Metal seats to be full size (same as the resilient seats) in order to provide for ability to handle 800°F, pressures up to 1440 psig and pressure drops to 500 psi for liquids and 300 psi for steam.

Seats to be available in various openings for specific Cv and specific characteristics.

Seats to be available with a slotted opening for linear control characteristics.

Valves to offer rangeability in excess of two hundred to one if needed.

Valves to be bi-directional.

Valves to be available with a resilient upstream or downstream seat to reduce torque and provide tight shutoff.

Ball to be round and be coated with a hard nickel coating to provide for smooth control and long life.

Ball and stem engagement to be free of play to eliminate hysteresis.

The characterized seat to provide for shearing action in handling slurries and to be abrasion resistant.

Valve to be equipped with compact rotary pneumatic or electric actuator.

The valve should be available with inherent characteristics, linear and equal percentage or other characteristics as needed.

The valve to be rotary design, compact and low weight.

The valve to be available in one-piece flanged, flangeless wafer design, or three-piece body with various end connections.

The valve should be constructed with minimum parts and be easy to repair if necessary.

#### Valve Torque:

Before the actuator can be sized for any given application, determine the amount of torque required by the valve.

For complete valve operating torque data, refer to the Worcester Controls Actuator Sizing Manual. This publication explains the concept of valve torque, presents torque curves for each material, and provides output torque figures for the Series 39 pneumatic and Series 75 electric actuators.

#### Pneumatic Control:

Series 39 Actuator — Refer to brochure FCD WCABR1003.

#### Pneumatic Control Options:

PM-15 Pneumatic and Electro-Pneumatic Positioners — Refer to brochure FCD WCABR1032.

MAStermind dribble feed control

Pulsair Analog/Digital Positioner — Refer to brochures FCD WCABR1018 and FCD WCABR1019.

#### Electronic/Computer Control:

Series 75 Actuator — Refer to brochure FCD WCABR1014.

#### Electronic Control Options:

Step Control: I-75 Circuit Board — Refer to brochure FCD WCABR1046.

Analog control: AF 17 Positioner — Refer to brochure FCD WCABR1000.

Digital/Analog Control: DFP-17 Positioner — Refer to brochure FCD WCABR1021.

P.I.D. Control: DFC-17 Controller — Refer to brochure FCD WCABR1021.

## How to Order Characterized Seat Control Valves

1"	CPT 44	4	6	P	M	SE	A30
Valve Size	Valve Series	Body/Pipe Ends	Ball /Stem	Round Port Seal	Body Seals	End Connections	Specify Characterized Seat
¼"	<b>CPT 44</b> <b>CPT94</b> 3-piece <b>C44</b> Cryogenic*	<b>4:</b> Carbon Steel	<b>6:</b> 316 Ni Plt Ball, 17-4 stem	<b>T:</b> Virgin PTFE	<b>M:</b> 316/TFE "S" gasket	<b>SE:</b> Female NPT	Specify Metallic seat material code and configuration <b>15:</b> 15° <b>30:</b> 30° <b>60:</b> 60° <b>90:</b> 90° <b>120:</b> 120° <b>02:</b> 1/64 SLOT <b>03:</b> 1/32 SLOT <b>06:</b> 1/16 SLOT <b>12:</b> 1/8 SLOT
½"		<b>6:</b> 316 Stainless Steel	<b>S:</b> Stellite Ball, 17-4 stem	<b>P:</b> Polyfill	<b>G:</b> Graphite/316 "S" gasket	<b>BW1:</b> Butt weld Sch 10 (SS only)	
¾"		<b>7:</b> Monel***	<b>C:</b> Hastelloy C Ball, Hast-C stem***	<b>H:</b> High-Per-Fill	<b>T:</b> PTFE	<b>BW4:</b> Butt weld Sch 40	
1"		<b>A:</b> Alloy 20***		<b>A:</b> Metal A	<b>B:</b> Buna	<b>BW5:</b> Butt weld Sch 5 (SS only)	
1 ½"		<b>C:</b> Hastelloy-C***		<b>C:</b> Hastelloy-C	<b>N:</b> Neoprene	<b>BW8:</b> Butt weld Sch 80	
2"		<b>1:</b> Brass		<b>S:</b> Stellite 6	<b>E:</b> EPDM	<b>XB0:</b> Extended Butt weld (OD Tube)	
3"	<b>CPT151</b> Wafer 150 <b>CPT301</b> Wafer 300 <b>C151/301</b> Cryo**			<b>U:</b> UHMWPE	<b>XB(n):</b> Extended Butt weld (n=Sch)	<b>SW:</b> Socket weld (pipe sizes)	
4"				<b>V:</b> Vee-Twin****	<b>U:</b> UHMWPE	<b>SWO:</b> Socket weld (Tube OD sizes)	
½"	<b>CPT51</b> Flgd 150 <b>CPT52</b> Flgd 300 <b>CPT94</b> Flgd 150 <b>CPT94</b> Flgd 300 <b>C51, C52</b> Cryo**					<b>150:</b> ASME Class 150 Flanges	
1"						<b>300:</b> ASME Class 300 Flanges	
1 ½"							
2"							
3"							
4"							

94 rated to -20°F

\*Cryo: Brass and stainless only

\*\*Cryo in stainless only

\*\*\*3-piece only

\*\*\*\*All 3-piece valves. Flanged bodies 3" & 4" only

**CAUTION:** Ball valves can retain pressurized media in the body cavity when closed. Use care when disassembling. Always open valve to relieve pressure prior to disassembly.

DataFlo C™, DataFlo P™, Polyfill® and PULSAIR® are registered trademarks of Flowserve Corporation.

Hastelloy® is a registered trademark of Haynes International.

Inconel® and Monel® are registered trademarks of Inco Alloys International.

Grafoil® is a registered trademark of Union Carbide.

## Characterized Seat Selection/Sizing Information

There are many control valve sizing formulas used by the process industries some very complicated and cumbersome, some simple. Flowserve has decided to provide solid, field-proven sizing information separate from this brochure. If using your personal calculator, use the Flowserve formulas found in Technical Paper #6 (TP-6). Ask for Worcester Controls PC compatible Control Valve Sizing Program.

Available on 3½" floppy disks or downloadable from our website, [www.flowserve.com](http://www.flowserve.com), the program is based on ISA formulas and includes instructions.

Below is Cv information for standard seats. Please contact Flowserve if you need special Cv or information regarding the Cv of a special opening.

### Flow Coefficient – Cv – Characterized Seat Control Valves

Valve Size	Line Size	Percent of Rated Travel (Degree of Rotation)										
		0 (0)	10 (9)	20 (18)	30 (27)	40 (36)	50 (45)	60 (54)	70 (63)	80 (72)	90 (81)	100 (90)
½" (¼" wide slot)	½"	0	.02	.025	.035	.06	.08	.09	.10	.11	.125	.14
¼" ½" (½" wide slot)	½"	0	.02	.03	.07	.12	.16	.20	.24	.28	.32	.36
	¾"	0	.02	.03	.07	.10	.14	.18	.21	.25	.29	.32
	1"	0	.02	.03	.06	.10	.13	.16	.18	.21	.27	.30
¼" ½" (⅙" wide slot)	½"	0	.02	.07	.20	.33	.46	.60	.73	.86	.99	1.10
	¾"	0	.02	.06	.18	.29	.41	.53	.65	.77	.88	.98
	1"	0	.02	.06	.17	.27	.38	.50	.61	.71	.82	.91
½" 15°V	½"	0	.02	.07	.19	.30	.45	.73	.94	1.29	1.64	1.91
	¾"	0	.02	.06	.16	.26	.40	.64	.83	1.14	1.44	1.68
	1"	0	.02	.06	.13	.20	.30	.48	.62	.85	1.08	1.26
¼" ½" 30°V	½"	0	.02	.10	.20	.34	.55	.83	1.11	1.59	2.08	2.50
	¾"	0	.02	.09	.18	.30	.49	.74	.99	1.41	1.85	2.22
	1"	0	.02	.08	.17	.28	.46	.69	.92	1.32	1.73	2.07
¼" ½" 60°V	½"	0	.02	.12	.33	.90	.84	1.35	1.95	3.10	4.37	5.92
	¾"	0	.02	.10	.29	.44	.75	1.20	1.74	2.76	3.90	5.27
	1"	0	.02	.10	.27	.41	.70	1.12	1.62	2.57	3.63	4.91
½" 90°V	½"	0	.02	.25	.39	.49	.92	1.49	2.20	3.60	5.40	6.80
	¾"	0	.02	.23	.35	.44	.83	1.34	1.98	3.24	4.86	6.12
	1"	0	.02	.21	.32	.41	.76	1.24	1.83	2.99	4.48	5.64
½" 120°V	½"	0	.02	.27	.43	.66	1.00	1.70	2.40	4.00	6.00	7.50
¾" (⅙" wide slot)	¾"	0	.02	.04	.08	.13	.18	.23	.27	.32	.37	.41
	1"	0	.02	.03	.08	.12	.17	.21	.23	.27	.34	.39
	1½"	0	.02	.02	.07	.11	.15	.20	.19	.22	.32	.36
¾" (⅙" wide slot)	¾"	0	.02	.08	.23	.38	.52	.68	.83	.98	1.13	1.25
	1"	0	.02	.07	.20	.32	.46	.59	.73	.87	.99	1.10
	1½"	0	.02	.06	.18	.28	.41	.52	.64	.76	.86	.97
¾" (⅙" wide slot)	¾"	0	.02	.14	.39	.65	.90	1.18	1.44	1.69	1.94	2.16
	1"	0	.02	.12	.33	.55	.77	1.00	1.22	1.44	1.65	1.84
	1½"	0	.02	.10	.28	.47	.65	.85	1.03	1.22	1.40	1.57

Cv is defined as the flow of liquid in gallons per minute through a valve with a pressure drop of 1 psi across the valve.

FL	0	.96	.95	.94	.93	.92	.90	.88	.86	.82	.75
Xt	0	.98	.77	.71	.67	.64	.63	.62	.55	.43	.40

FL = Liquid Pressure Recovery Factor Xt = Pressure Drop Ratio Factor (Gas)

**Flow Coefficient – Cv – Characterized Seat Control Valves**

Valve Size	Line Size	Percent of Rated Travel (Degree of Rotation)										
		0 (0)	10 (9)	20 (18)	30 (27)	40 (36)	50 (45)	60 (54)	70 (63)	80 (72)	90 (81)	100 (90)
¾" 15°V	¾"	0	.02	.08	.20	.28	.44	.71	.86	1.20	1.52	1.81
	1"	0	.02	.07	.18	.27	.43	.70	.85	1.18	1.49	1.76
	1½"	0	.02	.06	.16	.23	.37	.60	.74	1.00	1.29	1.52
¾" 30°V	¾"	0	.02	.11	.24	.41	.67	1.00	1.39	1.94	2.55	3.04
	1"	0	.02	.09	.21	.35	.59	.88	1.23	1.69	2.24	2.66
	1½"	0	.02	.08	.19	.31	.51	.78	1.08	1.47	1.96	2.33
¾" 60°V	¾"	0	.02	.13	.36	.55	.97	1.55	2.25	3.56	5.01	6.74
	1"	0	.02	.13	.34	.51	.91	1.44	2.10	3.32	4.66	6.28
	1½"	0	.02	.13	.31	.48	.84	1.35	1.95	3.09	4.34	5.85
¾" 90°V	¾"	0	.02	.38	.60	.75	1.42	2.29	3.38	5.53	8.31	10.46
	1"	0	.02	.33	.53	.66	1.25	2.02	2.97	4.87	7.31	9.20
	1½"	0	.02	.32	.50	.63	1.19	1.92	2.84	4.65	6.98	8.79
1" (1/32 wide slot)	1"	0	.02	.06	.14	.22	.29	.37	.45	.53	.60	.68
	1½"	0	.02	.06	.13	.19	.26	.33	.40	.47	.54	.61
	2"	0	.02	.05	.12	.18	.24	.31	.33	.39	.50	.57
1" (1/16 wide slot)	1"	0	.02	.13	.38	.63	.87	1.14	1.39	1.63	1.88	2.09
	1½"	0	.02	.11	.34	.55	.78	1.01	1.23	1.46	1.67	1.86
	2"	0	.02	.11	.32	.51	.72	.95	1.16	1.35	1.56	1.73
1" (1/8 wide slot)	1"	0	.02	.23	.66	1.09	1.52	1.99	2.42	2.85	3.28	3.64
	1½"	0	.02	.20	.57	.95	1.32	1.73	2.10	2.48	2.85	3.17
	2"	0	.02	.19	.54	.89	1.25	1.63	1.98	2.34	2.69	2.98
1" 15°V	1"	0	.02	.14	.42	.66	1.04	1.70	2.13	2.87	3.68	4.32
	1½"	0	.02	.12	.37	.57	.90	1.48	1.85	2.50	3.20	3.76
	2"	0	.02	.11	.33	.52	.82	1.34	1.68	2.27	2.91	3.41
1" 30°V	1"	0	.02	.21	.56	.96	1.58	2.39	3.43	4.62	6.15	7.26
	1½"	0	.02	.16	.44	.75	1.23	1.86	2.68	3.60	4.80	5.66
	2"	0	.02	.15	.40	.69	1.14	1.72	2.47	3.33	4.43	5.23
1" 60°V	1"	0	.02	.30	.78	1.24	2.27	3.59	5.28	8.29	11.60	15.50
	1½"	0	.02	.23	.61	.97	1.77	2.80	4.12	6.47	9.05	12.10
	2"	0	.02	.22	.56	.89	1.63	2.58	3.80	5.97	8.35	11.20
1" 90°V	1"	0	.02	.48	1.23	2.30	3.50	5.40	7.70	10.80	12.10	19.70
	1½"	0	.02	.42	1.08	2.02	3.08	4.75	6.78	9.50	10.65	17.34
	2"	0	.02	.38	.98	1.84	2.80	4.32	6.16	8.64	9.68	15.76
1" 120°V	1"	0	.02	1.10	1.80	2.60	4.00	6.50	9.80	15.80	24.20	29.80

Cv is defined as the flow of liquid in gallons per minute through a valve with a pressure drop of 1 psi across the valve.

FL	0	.96	.95	.94	.93	.92	.90	.88	.86	.82	.75
Xt	0	.98	.77	.71	.67	.64	.63	.62	.55	.43	.40

FL = Liquid Pressure Recovery Factor Xt = Pressure Drop Ratio Factor (Gas)



### Flow Coefficient – Cv – Characterized Seat Control Valves

Valve Size	Line Size	Percent of Rated Travel (Degree of Rotation)										
		0 (0)	10 (9)	20 (18)	30 (27)	40 (36)	50 (45)	60 (54)	70 (63)	80 (72)	90 (81)	100 (90)
1½" (1/32 wide slot)	1½"	0	.02	.10	.22	.34	.46	.58	.70	.82	.94	1.06
	2"	0	.02	.09	.20	.31	.42	.54	.59	.69	.88	1.00
	2½"	0	.02	.08	.19	.29	.39	.50	.49	.58	.81	.93
1½" (1/16 wide slot)	1½"	0	.02	.21	.59	.98	1.36	1.78	2.16	2.55	2.93	3.26
	2"	0	.02	.21	.56	.91	1.26	1.68	2.03	2.35	2.73	3.03
	2½"	0	.02	.20	.53	.85	1.17	1.58	1.90	2.17	2.55	2.82
1½" (1/8 wide slot)	1½"	0	.02	.36	1.05	1.73	2.41	3.15	3.83	4.51	5.20	5.77
	2"	0	.02	.31	.88	1.47	2.04	2.68	3.25	3.84	4.41	4.91
	2½"	0	.02	.25	.74	1.26	1.73	2.28	2.75	3.27	3.75	4.18
1½" 15°V	1½"	0	.02	.23	.71	1.42	2.35	3.44	5.04	6.92	9.24	11.06
	2"	0	.02	.19	.59	1.18	1.95	2.86	4.18	5.74	7.67	9.18
	2½"	0	.02	.17	.53	1.05	1.74	2.55	3.73	5.12	6.84	8.18
1½" 30°V	1½"	0	.02	.41	1.16	2.12	3.51	5.22	7.56	10.28	13.71	16.28
	2"	0	.02	.38	1.05	2.00	3.14	4.83	6.80	9.51	12.66	15.04
	2½"	0	.02	.36	.96	1.80	2.80	4.47	6.11	8.80	11.68	13.90
1½" 60°V	1½"	0	.02	.57	1.74	2.99	5.59	9.07	13.16	19.80	28.42	37.51
	2"	0	.02	.53	1.60	2.76	5.15	8.36	12.13	18.27	26.23	34.74
	2½"	0	.02	.48	1.47	2.54	4.74	7.70	11.19	16.87	24.21	32.16
1½" 90°V	1½"	0	.02	.66	2.48	4.59	8.74	14.55	20.63	30.07	44.25	57.75
	2"	0	.02	.55	2.08	3.86	7.34	12.22	17.33	25.26	37.17	48.51
	2½"	0	.02	.51	1.84	3.40	6.47	10.77	15.27	22.25	32.75	42.74
2" 15°V	2"	0	.02	.33	1.02	2.03	3.36	4.92	7.20	9.88	13.20	15.80
	2½"	0	.02	.29	.91	1.81	2.99	4.38	6.41	8.79	11.75	14.06
	3"	0	.02	.26	.82	1.62	2.69	3.94	5.76	7.51	10.56	12.64
2" 30°V	2"	0	.02	.55	1.72	3.41	5.65	8.26	12.10	16.60	22.20	26.50
	3"	0	.02	.45	1.41	2.80	4.63	6.77	9.92	13.60	18.20	21.70
	4"	0	.02	.41	1.27	2.52	4.18	6.11	8.95	12.30	16.40	19.60
2" 60°V	2"	0	.02	.70	2.64	4.90	9.32	15.50	22.20	32.10	47.20	61.60
	3"	0	.02	.57	2.16	4.02	7.64	12.70	18.20	26.30	38.70	50.50
	4"	0	.02	.52	1.95	3.63	6.90	11.50	16.40	23.80	34.90	45.60
2" 90°V	2"	0	.02	.88	3.30	6.13	11.65	19.40	27.50	40.10	59.00	77.00
	2½"	0	.02	.79	2.94	5.46	10.39	17.27	24.48	35.69	52.51	68.53
	3"	0	.02	.73	2.74	5.09	10.37	17.27	22.83	33.28	48.97	63.91
2" 120°V	2"	0	.02	1.86	5.25	10.30	15.80	25.30	37.10	59.50	91.80	110.80

Cv is defined as the flow of liquid in gallons per minute through a valve with a pressure drop of 1 psi across the valve.

FL	0	.96	.95	.94	.93	.92	.90	.88	.86	.82	.75
Xt	0	.98	.77	.71	.67	.64	.63	.62	.55	.43	.40

FL = Liquid Pressure Recovery Factor Xt = Pressure Drop Ratio Factor (Gas)

### Flow Coefficient – Cv – Characterized Seat Control Valves

Percent of Rated Travel (Degree of Rotation)

Valve Size	Line Size	Percent of Rated Travel (Degree of Rotation)										
		0 (0)	10 (9)	20 (18)	30 (27)	40 (36)	50 (45)	60 (54)	70 (63)	80 (72)	90 (81)	100 (90)
3" 15°V	3"	0	.02	.56	1.90	4.20	6.10	8.50	12.30	16.90	20.20	24.40
	4"	0	.02	.39	1.33	2.94	4.27	5.95	8.61	11.83	14.14	17.08
	6"	0	.02	.31	1.05	2.31	3.36	4.68	6.77	9.30	11.11	13.42
3" 30°V	3"	0	.02	.75	2.68	6.00	10.20	16.90	24.50	33.90	44.80	54.20
	4"	0	.02	.54	1.93	4.32	7.34	12.20	17.60	24.40	32.30	39.00
	6"	0	.02	.41	1.47	3.30	5.61	9.30	13.50	18.60	24.60	29.80
3" 60°V	3"	0	.02	.95	4.25	10.10	18.60	29.40	46.30	67.20	94.40	124.60
	4"	0	.02	.68	3.06	7.27	13.40	21.20	33.30	48.40	68.00	89.70
	6"	0	.02	.52	2.34	5.56	10.20	16.20	25.50	37.00	51.90	68.50
3" 90°V	3"	0	.02	1.22	5.50	14.00	26.00	44.00	67.00	102.00	151.00	230.00
	4"	0	.02	.85	3.85	9.80	18.20	30.80	46.90	71.40	105.70	161.00
	6"	0	.02	.67	3.03	7.70	14.30	24.20	36.85	56.10	83.05	126.50
3" 120°V	3"	0	.02	2.40	11.50	26.00	39.70	65.00	96.00	157.00	235.00	293.00
4" 15°V	4"	0	.02	4.20	10.00	13.90	17.90	21.70	27.90	34.00	41.20	45.00
	6"	0	.02	2.77	6.66	9.17	11.81	14.32	18.41	22.44	27.19	29.70
	8"	0	.02	2.31	5.50	7.65	9.85	11.94	15.35	18.70	22.66	24.75
4" 30°V	4"	0	.02	.80	3.59	8.50	16.10	26.80	40.20	56.60	72.50	89.80
	6"	0	.02	.52	2.33	5.53	10.50	17.40	26.10	36.80	47.10	58.40
	8"	0	.02	.44	1.97	4.68	8.86	14.70	22.10	31.10	39.90	49.40
4" 60°V	4"	0	.02	.90	5.69	15.40	28.80	48.60	73.40	107.00	150.70	200.00
	6"	0	.02	.59	3.70	10.00	18.70	31.60	47.70	69.60	98.00	130.00
	8"	0	.02	.50	3.13	8.47	15.80	26.70	40.40	58.90	82.90	110.00
4" 90°V	4"	0	.02	2.00	9.00	23.00	42.00	72.00	110.00	167.00	250.00	380.00
	6"	0	.02	1.28	5.76	14.72	26.88	46.08	70.40	106.88	160.00	243.20
	8"	0	.02	1.10	4.95	12.65	23.10	39.60	60.50	91.85	137.50	209.00
4" 120°V	4"	0	.02	3.00	14.00	35.00	64.00	110.00	168.00	255.00	383.00	580.00
	6"	0	.02	2.00	9.00	22.00	40.00	69.00	106.00	161.00	240.00	365.00

Cv is defined as the flow of liquid in gallons per minute through a valve with a pressure drop of 1 psi across the valve.

FL	0	.96	.95	.94	.93	.92	.90	.88	.86	.82	.75
Xt	0	.98	.77	.71	.67	.64	.63	.62	.55	.43	.40

FL = Liquid Pressure Recovery Factor Xt = Pressure Drop Ratio Factor (Gas)



## Flow Coefficient – Cv – Vee-Twin Valves

Size	Type	Percent of Rated Travel (Degree of Rotation)										
		0 (0)	10 (9)	20 (18)	30 (27)	40 (36)	50 (45)	60 (54)	70 (63)	80 (72)	90 (81)	100 (90)
¼ or ½	1/64 slot	0.00	0.01	0.02	0.02	0.04	0.06	0.06	0.07	0.08	0.09	0.10
	1/32 slot	0.00	0.01	0.02	0.05	0.08	0.11	0.14	0.17	0.20	0.23	0.25
	1/16 slot	0.00	0.01	0.05	0.14	0.23	0.33	0.42	0.52	0.61	0.70	0.78
	15° V	0.00	0.01	0.05	0.13	0.21	0.32	0.52	0.66	0.91	1.16	1.35
	30° V	0.00	0.01	0.07	0.14	0.24	0.39	0.59	0.78	1.12	1.47	1.77
	60° V	0.00	0.01	0.08	0.23	0.64	0.59	0.95	1.38	2.19	3.09	4.19
	90° V	0.00	0.01	0.18	0.28	0.35	0.65	1.05	1.56	2.55	3.82	4.81
	120° V	0.00	0.01	0.19	0.30	0.47	0.71	1.20	1.70	2.83	4.24	5.30
¾	1/32 slot	0.00	0.01	0.03	0.06	0.09	0.13	0.16	0.19	0.23	0.26	0.29
	1/16 slot	0.00	0.01	0.06	0.16	0.27	0.37	0.48	0.59	0.69	0.80	0.88
	1/8 slot	0.00	0.01	0.10	0.28	0.46	0.64	0.83	1.02	1.19	1.37	1.53
	15° V	0.00	0.01	0.06	0.14	0.20	0.31	0.50	0.61	0.85	1.07	1.28
	30° V	0.00	0.01	0.08	0.17	0.29	0.47	0.71	0.98	1.37	1.80	2.15
	60° V	0.00	0.01	0.09	0.25	0.39	0.69	1.10	1.59	2.52	3.54	4.77
	90° V	0.00	0.01	0.27	0.42	0.53	1.00	1.62	2.39	3.91	5.88	7.40
	120° V	0.00	0.01	0.30	0.47	0.58	1.10	1.78	2.63	4.30	6.46	8.13
1	1/32 slot	0.00	0.01	0.04	0.10	0.16	0.21	0.26	0.32	0.37	0.42	0.48
	1/16 slot	0.00	0.01	0.09	0.27	0.45	0.62	0.81	0.98	1.15	1.33	1.48
	1/8 slot	0.00	0.01	0.16	0.47	0.77	1.07	1.41	1.71	2.01	2.32	2.57
	15° V	0.00	0.01	0.10	0.30	0.47	0.74	1.20	1.51	2.03	2.60	3.05
	30° V	0.00	0.01	0.15	0.40	0.68	1.12	1.69	2.43	3.27	4.35	5.13
	60° V	0.00	0.01	0.21	0.55	0.88	1.60	2.54	3.73	5.86	8.20	10.96
	90° V	0.00	0.01	0.34	0.87	1.63	2.47	3.82	5.44	7.64	8.55	13.93
	120° V	0.00	0.01	0.78	1.27	1.84	2.83	4.60	6.93	11.17	17.11	21.07
1 ½	1/32 slot	0.00	0.01	0.07	0.16	0.24	0.33	0.41	0.49	0.58	0.66	0.75
	1/16 slot	0.00	0.01	0.15	0.42	0.69	0.96	1.26	1.53	1.80	2.07	2.30
	1/8 slot	0.00	0.01	0.25	0.74	1.22	1.70	2.23	2.71	3.19	3.68	4.08
	15° V	0.00	0.01	0.16	0.50	1.00	1.66	2.43	3.56	4.89	6.53	7.82
	30° V	0.00	0.01	0.29	0.82	1.50	2.48	3.69	5.34	7.27	9.69	11.51
	60° V	0.00	0.01	0.40	1.23	2.11	3.95	6.41	11.43	14.00	20.09	26.52
	90° V	0.00	0.01	0.47	1.75	3.25	6.18	10.29	14.59	21.26	31.28	40.83
	120° V	0.00	0.01	0.71	2.65	4.91	9.35	15.56	22.06	32.16	47.32	61.76
2	15° V	0.00	0.01	0.23	0.72	1.44	2.38	3.48	5.09	6.99	9.33	11.17
	30° V	0.00	0.01	0.39	1.22	2.41	3.99	5.84	8.55	11.74	15.70	18.74
	60° V	0.00	0.01	0.49	1.87	3.46	6.59	10.96	15.70	22.69	33.37	43.55
	90° V	0.00	0.01	0.62	2.33	4.33	8.24	13.72	19.44	28.35	41.71	54.44
	120° V	0.00	0.01	1.32	3.71	7.28	11.17	17.89	26.23	42.07	64.90	78.34
3	15° V	0.00	0.01	0.40	1.34	2.97	4.31	6.01	8.70	11.95	14.28	17.25
	30° V	0.00	0.01	0.53	1.89	4.24	7.21	11.95	17.32	23.97	31.67	38.32
	60° V	0.00	0.01	0.67	3.00	7.14	13.15	20.79	32.73	47.51	66.74	88.09
	90° V	0.00	0.01	0.86	3.89	9.90	18.38	31.11	47.37	72.11	106.76	162.61
	120° V	0.00	0.01	1.70	8.13	18.38	28.07	45.25	67.87	111.00	166.15	207.15
4	15° V	0.00	0.01	2.97	7.07	9.83	12.66	15.34	19.73	24.04	29.13	31.82
	30° V	0.00	0.01	0.57	2.54	6.01	11.38	18.95	28.42	40.02	51.26	63.49
	60° V	0.00	0.01	0.64	4.02	10.89	20.36	34.36	51.89	75.65	106.54	141.40
	90° V	0.00	0.01	1.41	6.36	16.26	29.69	50.90	77.77	118.07	176.75	268.66
	120° V	0.00	0.01	2.12	9.90	24.75	45.25	77.77	118.78	180.29	270.78	410.06

Cv is defined as the flow of liquid in gallons per minute through a valve with a pressure drop of 1 psi across the valve.

FL	1	0.99	0.99	0.98	0.98	0.98	0.97	0.96	0.96	0.95	0.925
Xt	1	0.99	0.93	0.91	0.9	0.89	0.88	0.88	0.86	0.82	0.81

FL = Liquid Pressure Recovery Factor Xt = Pressure Drop Ratio Factor (Gas)

## Actuator Sizing – Determination of Valve Torque

### Standard Reduced Port Ball Valves

The valve torque curve (page 21) shows the torque requirements of ¼" through 10" Worcester ball valves as a function of differential pressure across the valve when the ball is in the closed position.

**NOTE:** These curves have been developed for applications involving CLEAN media.

Based on valve size, seat material and differential pressure across the valve (in the closed position), the amount of torque required by the ball valve can be determined by the following procedures:

1. Find the valve torque from the torque curves on page 21 by using the differential pressure across the valve in the closed position. To do this, locate the differential pressure on the horizontal axis of the chart and move up until you arrive at the appropriate valve size, transfer the intersecting point across to the vertical axis of the graph, and read the required torque.
2. Multiply this torque value by one or more of the application factor multipliers shown below. Maximum cumulative multiplier = 2.

#### Application factor

#### Multiplier

##### A. Service

On-off .....	1.0
Emergency shutdown cycled less than once per month .....	2.0
Throttling control with positioner.....	1.2
Applications with less than two cycles/day.....	1.2
Applications below -20°F.....	1.25

##### B. Media

Saturated steam.....	1.2
Clean saturated steam .....	1.0
Liquid, clean (particle free).....	1.0
Liquid, dirty (slurry), raw water.....	1.8
Gas, clean and wet.....	1.2
Gas, clean and dry (super heated steam).....	1.0
Gas, dirty (natural gas).....	1.5
Chlorine.....	1.5

### Series 94 Valves

Series 94 valves with TFE, reinforced TFE, Polyfill and Metal “A” seats with TFE stem seals use the same torque values as standard valves shown on page 21. Series 94 valves with UHMWPE, High-per Fill and Metal “G” seats use Grafoil stem seals, which have higher operating torques. See the note at the bottom of the curves on page 21 for the additional torque required with Grafoil packing.

### Actuator Selection

Once the torque requirements of the valve have been determined, the actuator can be properly sized.

#### Pneumatic Actuators

Before sizing the actuator for the valve, there are a few pieces of information which must be determined, including the style of actuator (Series 34 or 39), the minimum air supply pressure available, and the type of operation (double-acting or spring-return) that the actuator is to perform. If the actuator is to be spring-return, the failure mode (fail closed or fail open) must also be determined.

1. Double-acting operation — Select the actuator whose torque output, at the minimum air supply pressure, exceeds the calculated torque requirements of the valve. Actuator torque output charts are shown on pages 22 and 23.
2. Spring-return operation, fail closed — Select the actuator whose torque output, at the minimum air supply pressure, at the end of spring stroke, exceeds the torque required to close the valve.
3. Spring-return operation, fail open — Select the actuator whose torque output, at the minimum air supply pressure, at the end of air stroke, exceeds the torque required to close the valve.

#### Electric Actuators

There are a few terms associated with electric actuators that require definition. Actuator startup torque is the amount of torque initially produced by an actuator when starting from rest. Use startup torque when selecting an electric actuator for a ball valve. Actuator stall torque is the amount of torque produced by the actuator just prior to the point where the motor stalls.

Select the actuator whose startup torque output exceeds the breakaway torque requirements of the valve. Electric actuator torque outputs are shown on page 22.

For valves other than ball valves, actuators must be selected such that startup torque exceeds the maximum torque rating of the valve.

Before making a final selection, make sure that the electric actuator selected is available in the required voltage. Not all electric actuators are available in all voltages.

## Pressure Torque Data for CPT Control Valves

**Metal “A” and Metal “G” Characterized Seats with Metal “A” (A), Metal “G” (G), High-per Fill (X), fluoropolymer (T), Polyfill (P) Round Seats or Vee-Twin Configuration**

Valve size/seat	0	100	200	300	400	500
½" T,P	70	72	74	76	78	80
½" X,G,A	95	104	113	122	131	140
¾" T,P	80	86	92	98	104	110
¾" X,G,A	120	134	148	162	176	190
1" T,P	175	180	185	190	195	200
1" X,G,A	220	227	234	241	248	255
1 ½" T,P	280	288	296	304	312	320
1 ½" X,G,A	360	364	368	372	376	380
2" T,P	440	458	476	494	512	530
2" X,G,A	540	556	572	588	604	620
3" All seats	1200	1300	1400	1500	1600	1700
4" All seats	1800	2220	2640	3060	3480	3900
½" Vee-Twin	110	114	118	122	126	130
¾" Vee-Twin	140	145	150	155	160	165
1" Vee-Twin	260	264	268	272	276	280
1 ½" Vee-Twin	425	430	435	440	445	450
2" Vee-Twin	640	658	676	694	712	730
3" Vee-Twin	1400	1500	1600	1700	1800	1900
4" Vee-Twin	2300	2520	2740	2960	3180	3400

*\*For Series CPT 94 control valves with Grafoil stem seals, add the following torque values to the curve values above: ½" – ¾", 90 in-lb; 1½" – 2", 150 in-lb; 3" – 4", 200 in-lb.*

## Actuator Output Charts (in-lb)

### Series 39 – Double-acting

Actuator Size	Operating Pressure (psi)									
	30	40	50	60	70	80	90	100	110	120
5	33.6	48.6	59.7	73.5	86.3	97.4	106	126	137	148
10	80	125	160	200	245	270	310	350	385	425
15	155	240	300	370	460	510	580	650	725	790
20	285	435	545	680	840	935	1070	1200	1330	1460
25	590	785	980	1180	1375	1570	1770	1965	2160	2355
30	790	1200	1500	1860	2305	2580	2935	3290	3645	4000
33	1600	2230	2280	3520	4160	4800	5430	6070	6720	7330
35	2220	2975	3900	4800	5600	6400	7200	8000	8800	9600
40 Rev. 3	3510	4710	6170	7390	8710	10040	11400	12700	13970	15270
42 Rev. 3	6500	8700	10900	13090	15330	17530	19720	21920	24120	26310
45 Rev. 1	9000	12700	16100	19500	22700	26000	29400	32600	36000	39500
50 Rev. 1	13145	19000	24000	29000	34000	40000	45000	50000	55000	60000

## Actuator Output Charts (in-lb)

### Series 75 – Electric

Actuator Size	Startup Torque (in-lb)
10	120
12	180
15	260
20	480
22	720
23	950
25	1440
30	2400

### Series 39 – Spring-Return

		Operating Pressure											
		30 psi		40 psi		50 psi		60 psi		70 psi		80 psi	
Size	Stroke	Start	End	Start	End	Start	End	Start	End	Start	End	Start	End
<b>No. of Springs</b>						2		2		2		4	
0539	Air					28	15	35	30	50	40	45	30
	Spring					41	31	41	31	41	31	53	40
<b>No. of Springs</b>		2		4		6		8		8		10	
1039	Air	70	40	85	60	105	60	125	70	170	120	175	95
	Spring	58	35	60	35	95	55	25	75	125	75	160	95
1539	Air	140	80	130	85	200	125	240	150	200	165	325	190
	Spring	100	60	105	74	105	105	220	145	220	145	200	105
2039	Air	220	150	300	240	340	235	415	280	575	440	600	360
	Spring	140	96	190	126	300	195	400	265	400	265	505	335
2539	Air	220	110	560	400	600	350	730	420	925	655	980	550
	Spring	240	170	345	210	540	330	720	450	720	450	915	575
3039	Air	324	180	840	610	965	600	1130	690	1575	1145	1650	920
	Spring	456	264	560	340	870	535	1160	730	1160	730	1470	920
3339	Air			1550	1160	1810	1200	2060	1220	2700	1860	2950	1900
	Spring			1070	680	1680	1070	2300	1460	2300	1460	2900	1850
3539	Air	1560	1260	2100	1470	2360	1450	2850	1730	3570	2615	3850	2210
	Spring	900	720	1330	850	2070	1330	2770	1815	2770	1815	3500	2300
4039	Air			3410	2300	3980	2350	4470	2390	5620	3450	6150	3500
	Spring			2490	1500	3730	2240	4970	2980	4970	2980	6210	3740
4239	Air			6550	4520	7280	4140	7960	3390	10510	6190	10920	5590
	Spring			4560	2390	6900	3800	9290	4870	9290	4890	11720	6370
<b>No. of Springs</b>				12		16		18		22		24	
4539	Air			8700	4000	10600	4300	13200	5900	14900	6100	17600	8000
	Spring			8300	4000	11800	5500	15600	6300	16600	7800	18000	8400
5039	Air			12500	6000	15500	6000	19500	8500	21800	8000	26500	11500
	Spring			13000	6500	18000	8500	20500	9500	26000	12200		13500

## Dimensions for CPT 44 Control Valves

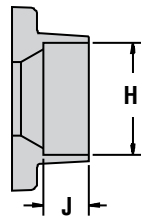
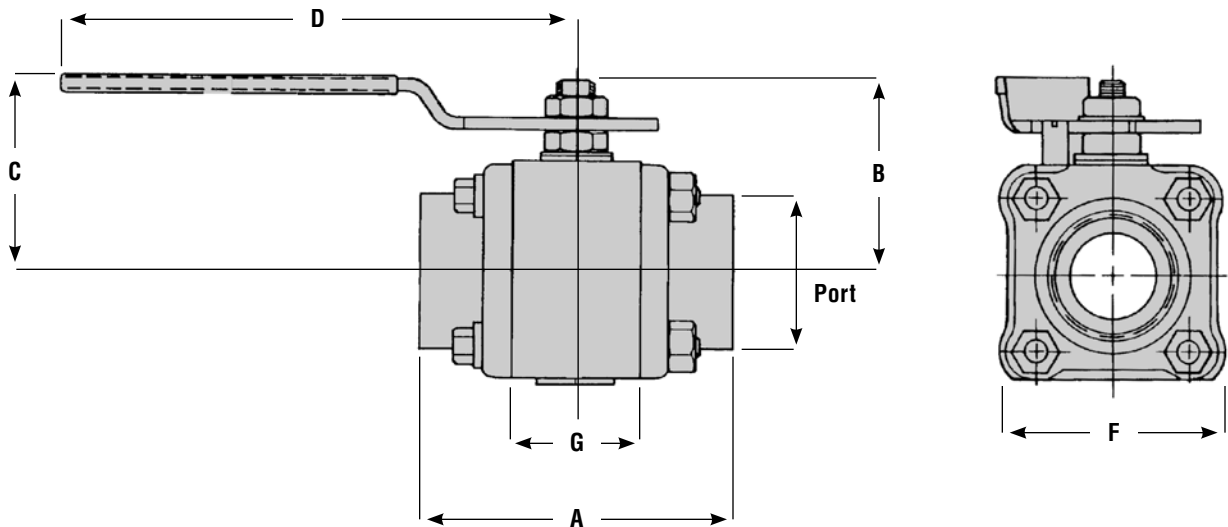

**Socket Weld  
SW**

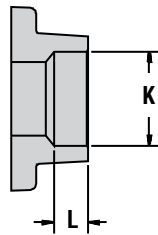

**O.D. Tube End  
SWO**

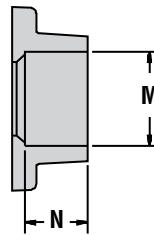

**Tube End TE  
K, L, OR M  
(Copper Tube)**

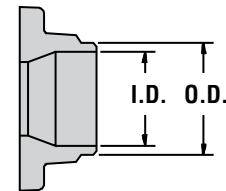

**Butt Weld BW  
SCH. 5, 10 (Stainless Steel)  
SCH. 4, 80 (Carbon Steel)**

\*The inside configuration of O.D. tube pipe ends varies by size and material.  
\*For XBO and TC ends, call Flowserve.

### Dimensions in inches (mm)

Valve Size	A	B	C	D	F	G	Socket Weld SW		O.D. Tube End SWO		O.D. Tube End TE		Butt Weld Stainless Steel				Butt Weld Carbon Steel				Port	Approx. Weight lb (kg)
							H	J	K	L	M	N	BW5 Sch. 5		BW1 Sch. 10		BW4 Sch. 40		BW8 Sch. 80			
													O.D.	I.D.	O.D.	I.D.	O.D.	I.D.	O.D.	I.D.		
1/4"	2.54 (64.5)	1.55 (39.4)	1.76 (44.7)	5.53 (140)	1.75 (44.5)	.813 (20.7)	.555 (14.1)	.44 (11.2)	—	—	.378 (9.6)	.37 (9.4)	—	—	.55 (14.0)	.406 (10.3)	.550 (14.0)	.344 (8.7)	—	—	.44 (11.2)	1.10 (.50)
3/8"	2.54 (64.5)	1.55 (39.4)	1.76 (44.7)	5.53 (140)	1.75 (44.5)	.813 (20.7)	.690 (17.5)	.44 (11.2)	—	—	.503 (12.8)	.44 (11.2)	—	—	.67 (17.0)	.547 (13.9)	.670 (17.0)	.516 (13.1)	—	—	.44 (11.2)	1.10 (.50)
1/2"	2.54 (64.5)	1.55 (39.4)	1.76 (44.7)	5.53 (140)	1.75 (44.5)	.813 (20.7)	.855 (21.7)	.44 (11.2)	.510 (13.0)	.44 (11.2)	.628 (15.6)	.56 (14.2)	.840 (21.3)	.710 (18.0)	.84 (21.3)	.672 (17.1)	.840 (21.3)	.625 (15.9)	.840 (21.3)	.550 (14.0)	.44 (11.2)	1.10 (.50)
3/4"	2.76 (70.1)	1.64 (41.7)	1.86 (47.2)	5.53 (140)	2.00 (50.8)	.969 (24.6)	1.065 (27.1)	.56 (14.2)	.760 (19.3)	.56 (14.2)	.878 (22.3)	.81 (20.6)	1.05 (26.7)	.920 (23.4)	1.05 (26.7)	.875 (22.2)	1.05 (26.7)	.812 (20.6)	1.05 (26.7)	.753 (19.1)	.56 (14.2)	1.75 (.79)
1"	3.66 (93.0)	2.19 (55.6)	2.28 (57.9)	6.53 (166)	2.38 (60.5)	1.25 (31.8)	1.330 (33.8)	.72 (18.3)	1.01 (25.7)	.56 (14.2)	1.129 (28.7)	.97 (24.5)	1.31 (33.3)	1.18 (30.1)	1.31 (33.3)	1.09 (27.8)	1.31 (33.3)	1.05 (26.6)	1.31 (33.3)	.957 (24.3)	.81 (20.6)	3.10 (1.41)
1 1/4"	4.16 (105)	2.38 (60.5)	2.47 (62.7)	6.53 (166)	2.70 (68.6)	1.63 (41.3)	1.675 (42.5)	.72 (18.3)	1.26 (32.0)	.62 (15.8)	1.379 (35.0)	1.03 (26.2)	1.66 (42.2)	1.53 (38.9)	1.66 (42.2)	1.44 (36.5)	1.66 (42.2)	1.38 (35.1)	1.66 (42.2)	1.27 (32.3)	1.00 (25.4)	4.50 (2.04)
1 1/2"	4.50 (114)	2.88 (73.2)	2.83 (71.9)	8.03 (204)	3.16 (80.3)	1.91 (48.4)	1.915 (48.6)	.72 (18.3)	1.51 (38.4)	.62 (15.8)	1.629 (41.4)	1.15 (29.2)	1.91 (48.5)	1.77 (45.0)	1.91 (48.5)	1.67 (42.5)	1.91 (48.5)	1.59 (40.5)	1.91 (48.5)	1.52 (38.6)	1.25 (31.8)	6.20 (2.82)
2"	4.94 (126)	3.06 (77.7)	3.02 (76.7)	8.03 (204)	3.56 (90.4)	2.22 (56.3)	2.406 (61.1)	.84 (21.3)	2.01 (51.1)	.67 (17.0)	2.129 (54.1)	1.15 (29.2)	2.38 (60.5)	2.24 (57.0)	2.38 (60.5)	2.15 (54.5)	2.38 (60.5)	2.06 (52.4)	2.38 (60.5)	1.93 (48.9)	1.50 (38.1)	9.50 (4.31)

## Dimensions for 94 Three-Piece

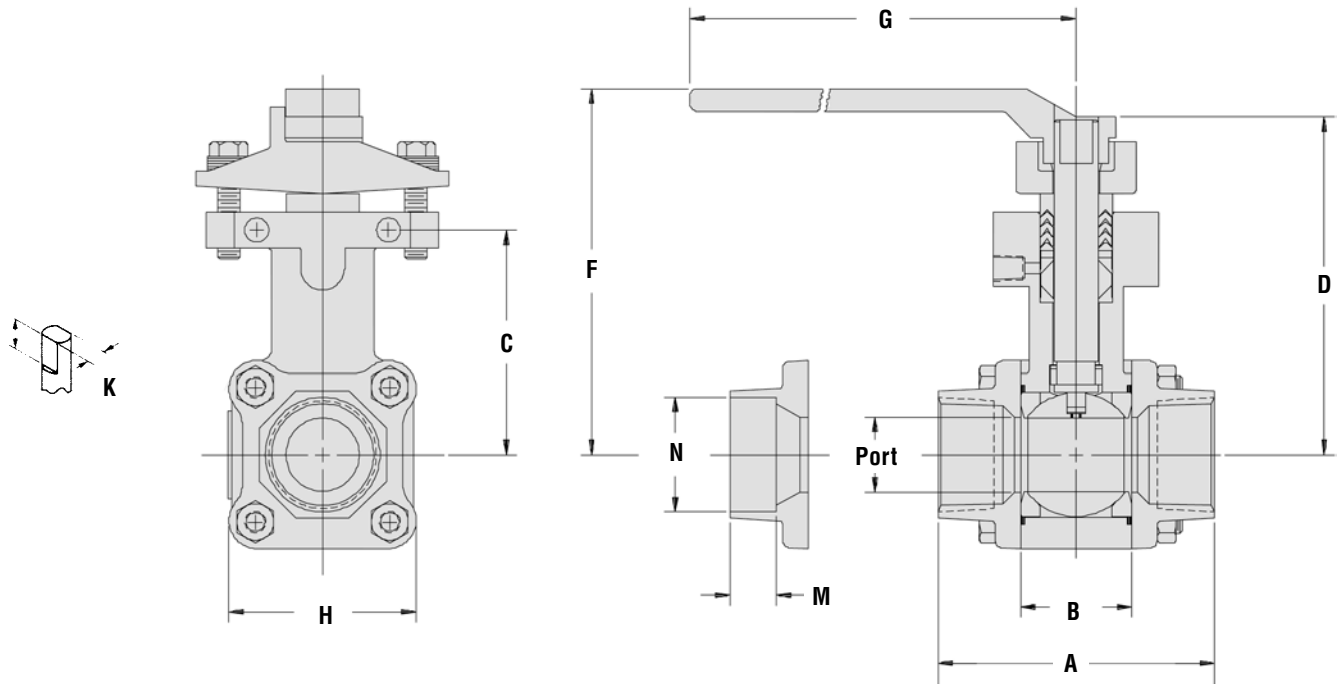

### 1/4"-2" 94 Three-Piece

Dimensions in inches (mm)

Valve Size	A	B	C	D	E	F	G	H	K	M	N	Port	Weight lb (kg)
1/4"	2.54 (64.52)	.813 (20.65)	2.67 (67.82)	4.40 (111.76)	.70 (17.78)	4.75 (120.65)	8.00 (203.20)	1.75 (44.45)	.296 (7.52)	.44 (11.18)	.555 (14.10)	.44 (11.18)	2 (.91)
3/8"	2.54 (64.52)	.813 (20.65)	2.67 (67.82)	4.40 (111.76)	.70 (17.78)	4.75 (120.65)	8.00 (203.20)	1.75 (44.45)	.296 (7.52)	.44 (11.18)	.690 (17.53)	.44 (11.18)	2 (.91)
1/2"	2.54 (64.52)	.813 (20.65)	2.67 (67.82)	4.40 (111.76)	.70 (17.78)	4.75 (120.65)	8.00 (203.20)	1.75 (44.45)	.296 (7.52)	.44 (11.18)	.855 (21.72)	.44 (11.18)	3 (1.4)
3/4"	2.76 (70.10)	.969 (24.61)	2.76 (70.10)	4.49 (114.05)	.70 (17.78)	4.84 (122.94)	8.00 (203.20)	2.00 (50.80)	.296 (7.52)	.56 (14.22)	1.065 (27.05)	.56 (14.22)	4 (1.8)
1"	3.66 (92.96)	1.250 (31.75)	3.18 (80.77)	4.91 (124.71)	.70 (17.78)	5.26 (133.60)	8.00 (203.20)	2.38 (60.45)	.343 (8.71)	.72 (18.29)	1.330 (33.78)	.81 (20.57)	5 (23)
1 1/4"	4.16 (105.66)	1.625 (41.27)	3.37 (85.60)	5.10 (129.54)	.70 (17.78)	5.45 (138.43)	8.00 (203.20)	2.70 (68.58)	.343 (8.71)	.72 (18.29)	1.675 (42.55)	1.00 (25.40)	10 (4.5)
1 1/2"	4.50 (114.36)	1.906 (48.41)	3.82 (97.03)	5.66 (143.76)	.75 (19.05)	6.14 (155.96)	10.00 (254.00)	3.16 (80.26)	.500 (12.70)	.72 (18.29)	1.915 (48.64)	1.25 (31.75)	11 (5.0)
2"	4.94 (125.48)	2.213 (56.21)	4.01 (101.85)	5.85 (148.59)	.75 (19.05)	6.33 (160.78)	10.00 (254.00)	3.56 (90.42)	.500 (12.70)	.84 (21.34)	2.406 (61.11)	1.50 (38.1)	13 (5.9)

## Dimensions for 1¼"–2" CPT 44 Series Valves Mounted to 25 and 30 39 Series Actuators with L93W Pulsair III Positioner

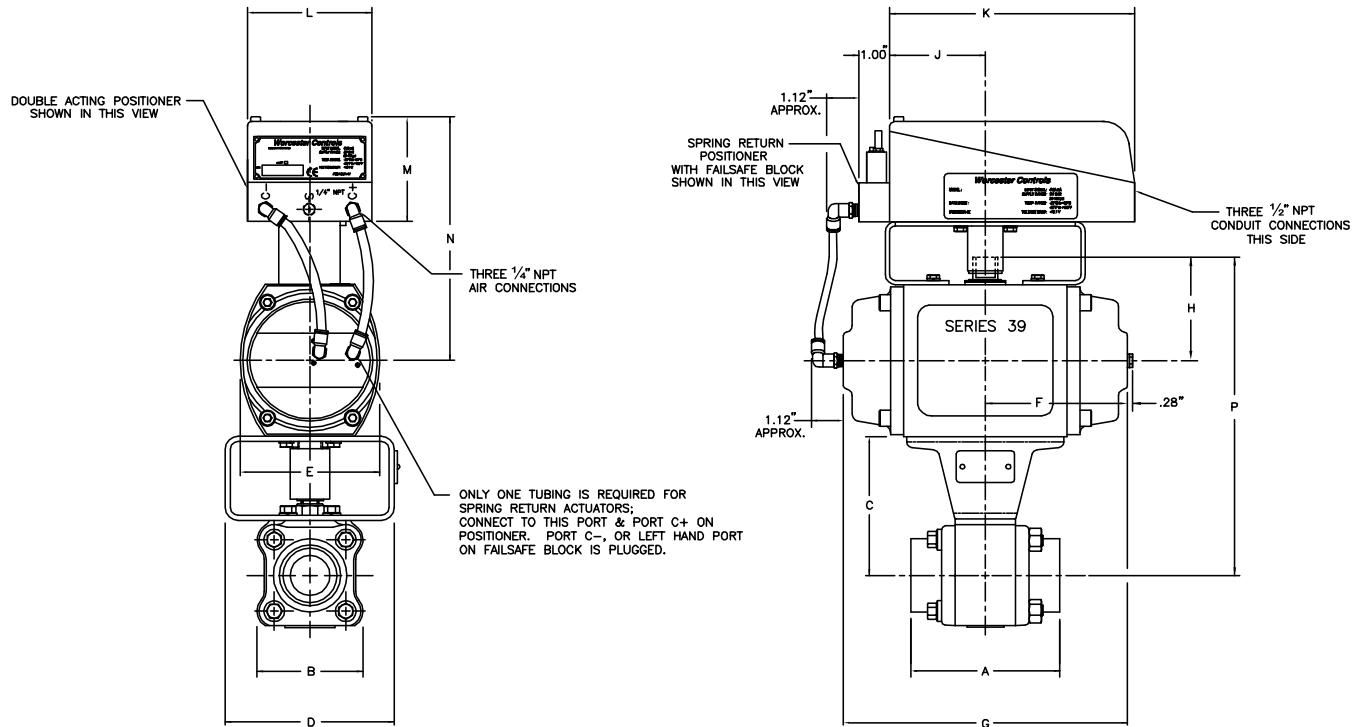

Actuator shown in the closed position with pistons together.  
 Dimensions for high temperature actuators are the same as the equivalent size standard temperature actuators.

### Dimensions in inches (mm)

Valve Size	Dimensions														Actuator		
	A	B	C	D	Act. Size	E	F	G	H	J	K	L	M	N	Valve Size	P	
1¼"	4.16	2.70	4.46	5.00	2539	5.34	5.31	10.62	4.07	3.00	7.91	4.00	3.23	8.29	1¼"	11.42	12.24
1½"	4.50	3.16	4.73	5.00	3039	6.10	6.39	12.77	4.48	3.00	7.91	4.00	3.23	8.70	1½"	11.69	12.51
2"	4.94	3.56	4.92	5.00											2"	11.88	12.70

## Dimensions for 39 Pneumatic Actuator with Pulsair® and Pulsair III Positioner

Dimensions in inches (mm)

Actuator Size D.A. or S.R.	C	E
10	3.05 (77.5)	1.52 (38.6)
15	3.84 (97.5)	1.86 (47.2)
20	4.62 (117.4)	2.30 (58.4)
25	5.31 (134.9)	2.67 (67.8)
30	6.39 (162.3)	3.05 (77.5)

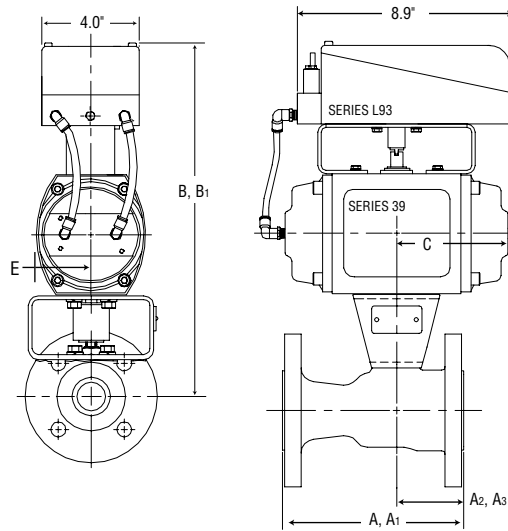

39 Actuator with Pulsair III Positioner

## 1/2"-2" CPT 51/52 and 1/2"-2" CPT 94 Flanged Control Valves 1/2"-2" S 51/52 Flanged Standard Seat Control Valves

Dimensions in inches (mm)

Valve Size	Face-to-face		Center-to-face		39 Pneumatic Actuator Direct-acting or Spring-return with Pulsair III Positioner		
	A 51 (150#)	A1 52 (300#)	A2 51 (150#)	A3 52 (300#)	Size	B - S 51/52, CPT 51/52	B1 CPT 94
1/2"	4.25 (108.0)	5.50 (139.7)	1.81 (45.97)	2.31 (58.67)	10	11.31 (287)	14.06 (357)
3/4"	4.62 (117.4)	6.0 (152.4)	1.94 (49.28)	2.44 (61.98)	10	11.40 (290)	14.15 (359)
					15	12.12 (308)	14.87 (378)
1"	5.00 (127.0)	6.50 (165.1)	2.25 (57.15)	2.75 (69.85)	15	12.36 (314)	15.29 (388)
					20	13.19 (335)	16.12 (409)
1 1/2"	6.50 (165.0)	7.50 (190.5)	2.45 (62.23)	2.95 (74.93)	20	14.15 (359)	16.80 (427)
					25	15.91 (404)	18.59 (472)
2"	7.00 (178.0)	8.50 (215.9)	2.67 (67.82)	3.17 (80.52)	20	14.34 (364)	16.99 (432)
					25	16.10 (409)	18.78 (477)
					30	16.92 (430)	19.60 (498)

## Dimensions for 39 Pneumatic Actuator with Pulsair III Positioner

Actuator Size D.A. or S.R.	C	E
25	5.31 (134.9)	2.67 (67.8)
30	6.39 (162.3)	3.05 (77.5)
33	7.83 (119.0)	4.04 (102.5)
35	8.31 (211.1)	4.17 (105.9)
40	10.00 (254.0)	4.82 (122.4)
42	12.12 (307.8)	5.57 (141.5)
45	11.43 (290.3)	6.60 (167.6)

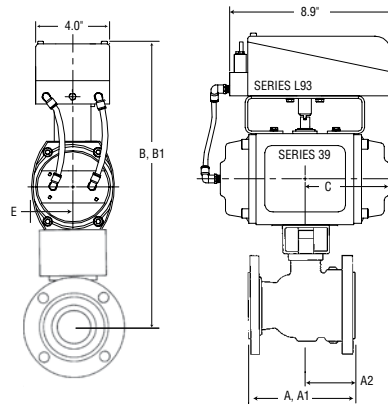

39 Actuator with Pulsair III Positioner

## 3" & 4" CPT 51/52 and 3" and 4" CPT 94 Flanged Control Valves 3"-8" 51/52 Flanged Standard Seat Control Valves

Dimensions in inches (mm)

Valve Size	Face-to-face			39 Pneumatic Actuator Direct-acting or Spring-return with Pulsair III Positioner			
	A (150#)	A1 (300#)	A2 (150, 300#)	Size	B 51/52	B CPT 51/52	B1 CPT 94
3"	8.00 (203.2)	11.12 (282.5)	3.62 (91.9)	25	18.21 (463)	18.21 (463)	19.13 (486)
				30	19.26 (489)	19.26 (489)	19.95 (507)
				33	21.42 (544)	21.42 (544)	22.55 (573)
				35	21.52 (547)	21.52 (547)	22.65 (575)
4"	9.00 (228.6)	12.00 (304.8)	4.00 (101.6)	30	19.86 (504)	19.86 (504)	20.55 (522)
				33	22.02 (559)	22.02 (559)	23.15 (588)
				35	22.12 (562)	22.12 (562)	23.25 (591)
				40	24.89 (632)	24.89 (632)	25.58 (650)

## Dimensions for Series CPT 151/301/4 Wafer-Style Control Valves

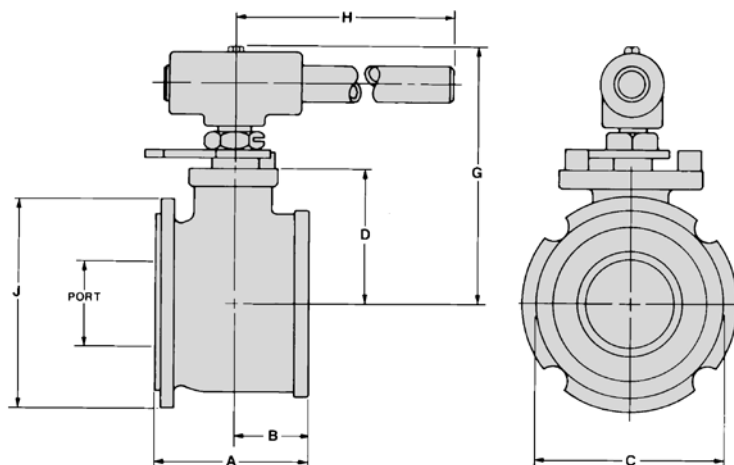

Dimensions in inches (mm)

Valve Size	A	B	C	D	G	H	J	Port Diameter	Approx. Weight lb (kg)
3"	4.50 (114.3)	2.25 (57.2)	5.31 (134.9)	3.88 (98.6)	7.22 (183.4)	22.00 (558.8)	5.88 (149.4)	2.50 (63.5)	21 (9.5)
4"	5.81 (147.6)	2.90 (73.7)	6.81 (173.0)	4.48 (113.8)	7.84 (199.1)	22.00 (558.8)	7.50 (190.5)	3.25 (82.6)	34 (15.4)

## Dimensions for Valve and 75 Electric Actuator

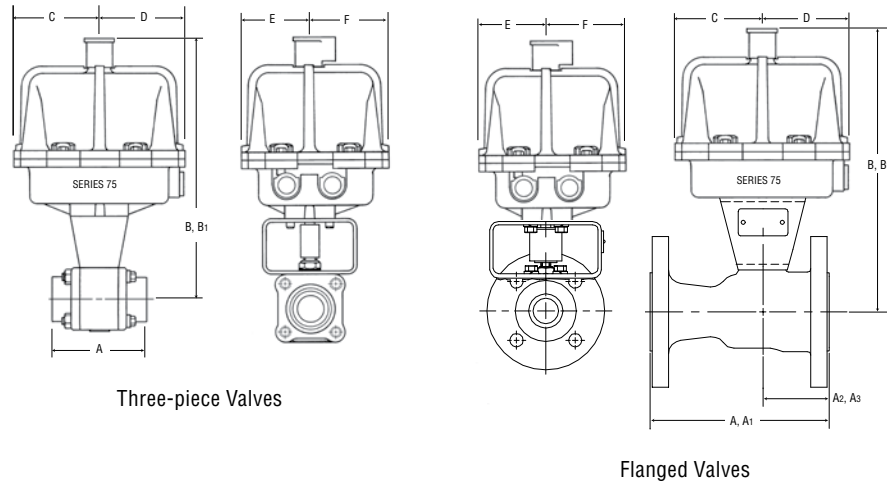

### 1/4"–2" S44, CPT 44, CPT 94 Three-piece Control Valves 1/2"–2" S 51/52, CPT 51/52, CPT 94 Flanged Control Valves

inches (mm)

Series 75 Electric Actuator†								
Valve Size	A	Face-to-face		Center to face		Size	B	B <sub>1</sub>
	Three-piece (SW, BW1, BW4)	A <sub>51</sub>	A <sub>1 52</sub>	A <sub>2 51</sub>	A <sub>3 52</sub>		S 44/51/52 & CPT 44/51/52	CPT 94
		(150#)	(300#)	(150#)	(300#)			
1/4", 1/2"	2.54 (64.5)	4.25 (108.0)	5.50 (139.7)	1.81 (45.97)	2.31 (58.67)	10 through 23	11.44 (291)	14.19 (360)
3/4"	2.76 (70.1)	4.62 (117.4)	6.0 (152.4)	1.94 (49.28)	2.44 (61.98)	10 through 23	11.53 (293)	14.28 (363)
1"	3.66 (93.0)	5.00 (127.0)	6.50 (165.1)	2.25 (57.15)	2.75 (69.85)	10 through 23	11.77 (299)	14.70 (373)
1 1/4" (S 44 only)	4.16 (105.7)	—	—	—	—	10 through 23	11.96 (304)	—
1 1/2"	4.50 (114.3)	6.50 (165.0)	7.50 (190.5)	2.45 (62.23)	2.95 (74.93)	10 through 23	12.73 (323)	15.38 (391)
2"*	4.94 (125.5)	7.00 (178.0)	8.50 (215.9)	2.67 (67.82)	3.17 (80.52)	22, 23*	12.92 (328)	15.56 (395)

Actuator Size	C	D	E	F
10 through 22	3.90 (99.1)	3.90 (99.1)	3.14 (79.8)	3.61 (91.7)
23 (and sizes 10 through 22 with "Z" enclosures)	4.23 (107.4)	4.23 (107.4)	3.48 (88.4)	3.97 (100.9)

\*A 2" CPT should not be sized with an electric actuator smaller than a 2275; a mechanical brake must also be ordered with this combination.

† B dimensions are for actuator sizes 10-22. Add 1.15" for 2375.

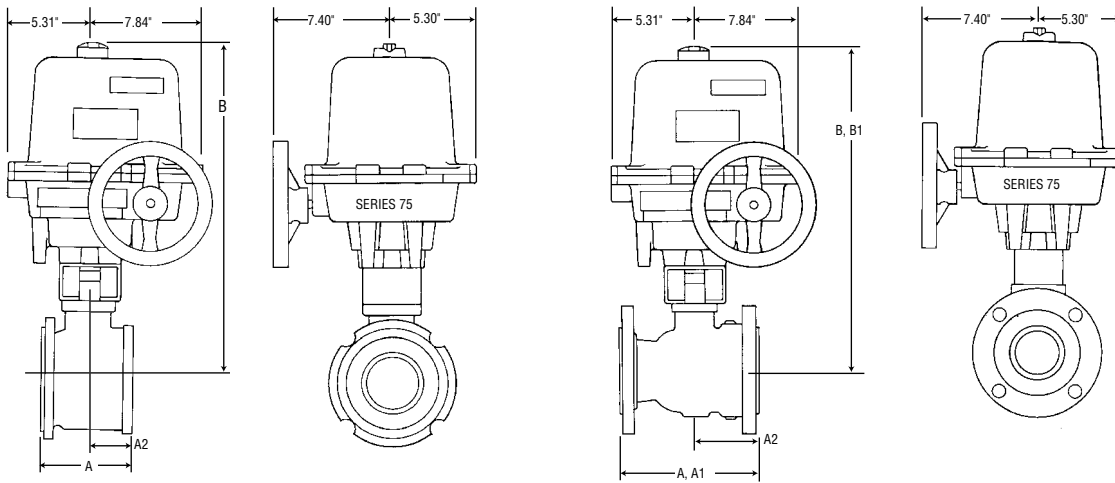

Wafer Valves

Flanged Valves

**3"-4" CPT 44 Wafer Control Valves**  
**3"-4" 151/301 Wafer Standard Seat Control Valves**

Series 75 Electric Actuator†				
Valve Size	Face-to-face		Size	B
	A	A <sub>2</sub>		
3"	4.50 (114.3)	2.25 (57.2)	25 and 30	21.64 (550)
4"	5.81 (147.6)	2.90 (73.7)	25 and 30	22.24 (565)

**3"-4" CPT 51/52/94 Flanged Valves**  
**3"-4" 51/52 Standard Seat Control Valves**

Series 75 Electric Actuator†						
Valve Size	Face-to-face			Size	B	B <sub>1</sub>
	A	A <sub>1</sub>	A <sub>2</sub>		CPT 51/52	CPT 94
	(150#)	(300#)	(150/300#)			
3"	8.00 (203.2)	11.12 (282.5)	3.62 (91.9)	25 and 30	21.64 (550)	22.33 (567)
4"	9.00 (228.6)	12.00 (304.8)	4.00 (101.6)	25 and 30	22.24 (565)	22.93 (582)



**Flowserve Corporation**  
**Flow Control**  
1978 Foreman Drive  
Cookeville, Tennessee 38501  
Phone: 931 432 4021  
Fax: 931 432 3105  
[www.flowserve.com](http://www.flowserve.com)

***To find your local Flowserve representative,  
visit [www.flowserve.com](http://www.flowserve.com) or call USA 1 800 225 6989***

FCD WCENBR1001-02 Printed in USA.

Flowserve Corporation has established industry leadership in the design and manufacture of its products. When properly selected, this Flowserve product is designed to perform its intended function safely during its useful life. However, the purchaser or user of Flowserve products should be aware that Flowserve products might be used in numerous applications under a wide variety of industrial service conditions. Although Flowserve can (and often does) provide general guidelines, it cannot provide specific data and warnings for all possible applications. The purchaser/user must therefore assume the ultimate responsibility for the proper sizing and selection, installation, operation, and maintenance of Flowserve products. The purchaser/user should read and understand the Installation Operation Maintenance (IOM) instructions included with the product, and train its employees and contractors in the safe use of Flowserve products in connection with the specific application.

While the information and specifications contained in this literature are believed to be accurate, they are supplied for informative purposes only and should not be considered certified or as a guarantee of satisfactory results by reliance thereon. Nothing contained herein is to be construed as a warranty or guarantee, express or implied, regarding any matter with respect to this product. Because Flowserve is continually improving and upgrading its product design, the specifications, dimensions and information contained herein are subject to change without notice. Should any question arise concerning these provisions, the purchaser/user should contact Flowserve Corporation at any one of its worldwide operations or offices.

© 2007 Flowserve Corporation, Irving, Texas, USA. Flowserve is a registered trademark of Flowserve Corporation.