



# TECHNICAL BULLETIN

## ***Valtek Multi-Z***

### Anti-Cavitation Control Valve

FCD VLENTB1631-00 12/11



***Experience In Motion***

## Index

Section	Page
Features .....	2
Specifications.....	3
Principal design .....	4
Principle of cavitation elimination .....	5
Bellows seal .....	6
Packing options .....	6
Soft seat.....	7
Gasket designs.....	8
Flow capacity and solid size .....	10
Construction and materials .....	12
Dimensions .....	13
Actuator mounting options .....	19

## Features

- Tolerance to solids in the medium
- Avoids cavitation
- Reduces noise
- Balanced and unbalanced design

**For a given valve size the extension varies according to number of stages while using the same bonnet and body**

Plug guiding in every stage (eliminates vibration)

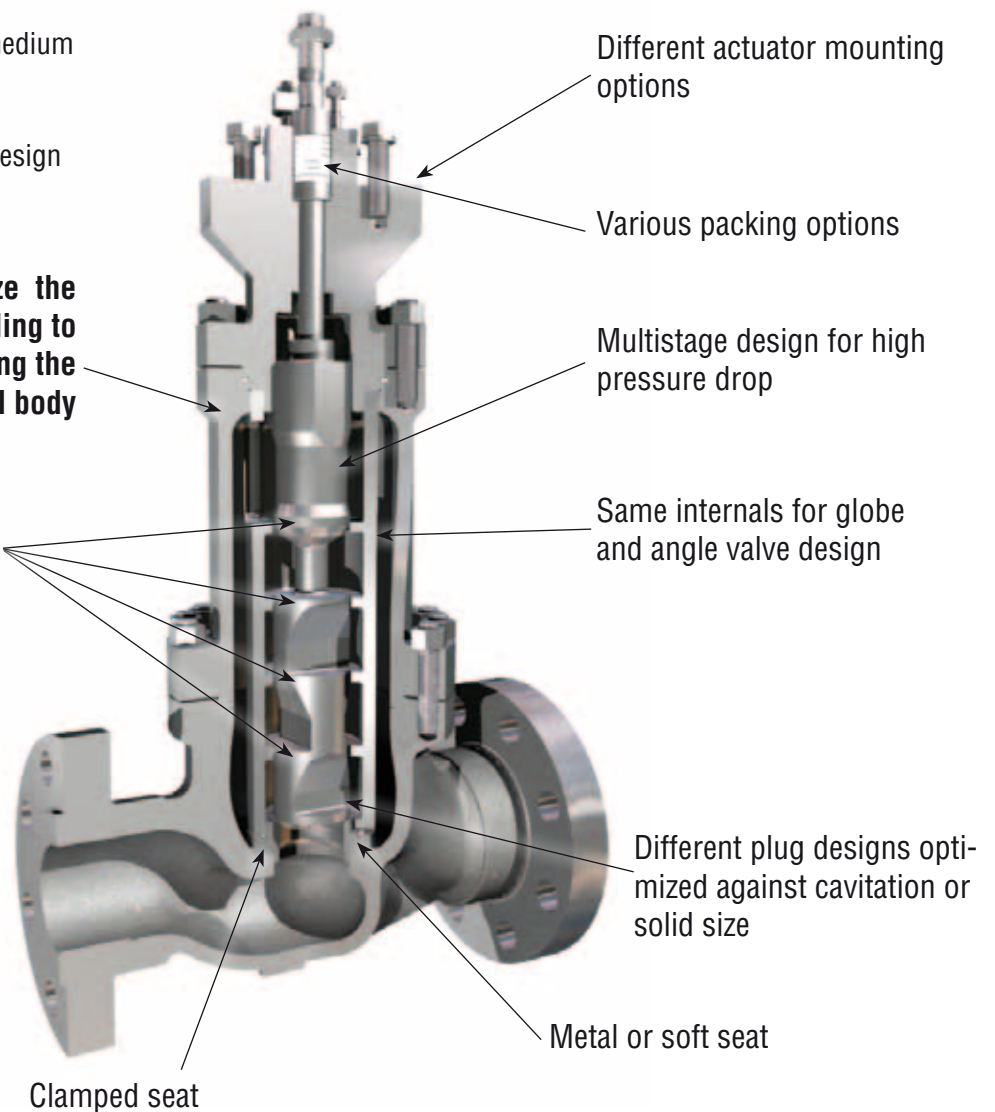

Different actuator mounting options

Various packing options

Multistage design for high pressure drop

Same internals for globe and angle valve design

Different plug designs optimized against cavitation or solid size

Metal or soft seat

Clamped seat

## Specifications

<b>Size</b>	ANSI 1 - 4 inch (globe) ANSI 1 - 8 inch and DIN DN 25 - 200 (angle); special sizes on request
<b>Pressure Class</b>	Class 300 - 1500; PN40-250
<b>Body Materials</b>	Carbon Steel (WCB, A105) Stainless Steel (CF8M, 316SS, 321SS) CrMo Steel (WC9, F22) Other materials are possible upon request
<b>Body Type</b>	Angle and Globe
<b>End Connections</b>	Weld ends Flanges per ANSI and DIN Screwed NPT (up to 2") Different inlet and outlet size others upon request
<b>Face to Face</b>	Globe ANSI / ISA 75.08.01 and ANSI / ISA 75.08.06 Globe DIN EN 558
<b>Trim Type</b>	Balanced or Unbalanced
<b>Trim Design</b>	Multistage Trim 3-6 stages (number of stages as required by service conditions) Venturi nozzle outlet optional
<b>Trim materials</b>	See table on page 13
<b>Flow Characteristic</b>	Linear, Modified Equal Percentage and custom engineered
<b>Stem Sealing</b> (see page 6)	Standard PTFE, Graphite Fugitive Emission according to ISO 15848 and TA-Luft Bellows
<b>Solid size</b>	0.2 to 12.7 mm - see pages 10 and 11 for details
<b>Actuator</b>	Spring Diaphragm Actuator Type KP (Stainless Steel) Spring Diaphragm Actuator Type FlowAct (Carbon Steel) Piston Actuator Type VL Electric Actuator Hydraulic Actuator

**Principle of Design**

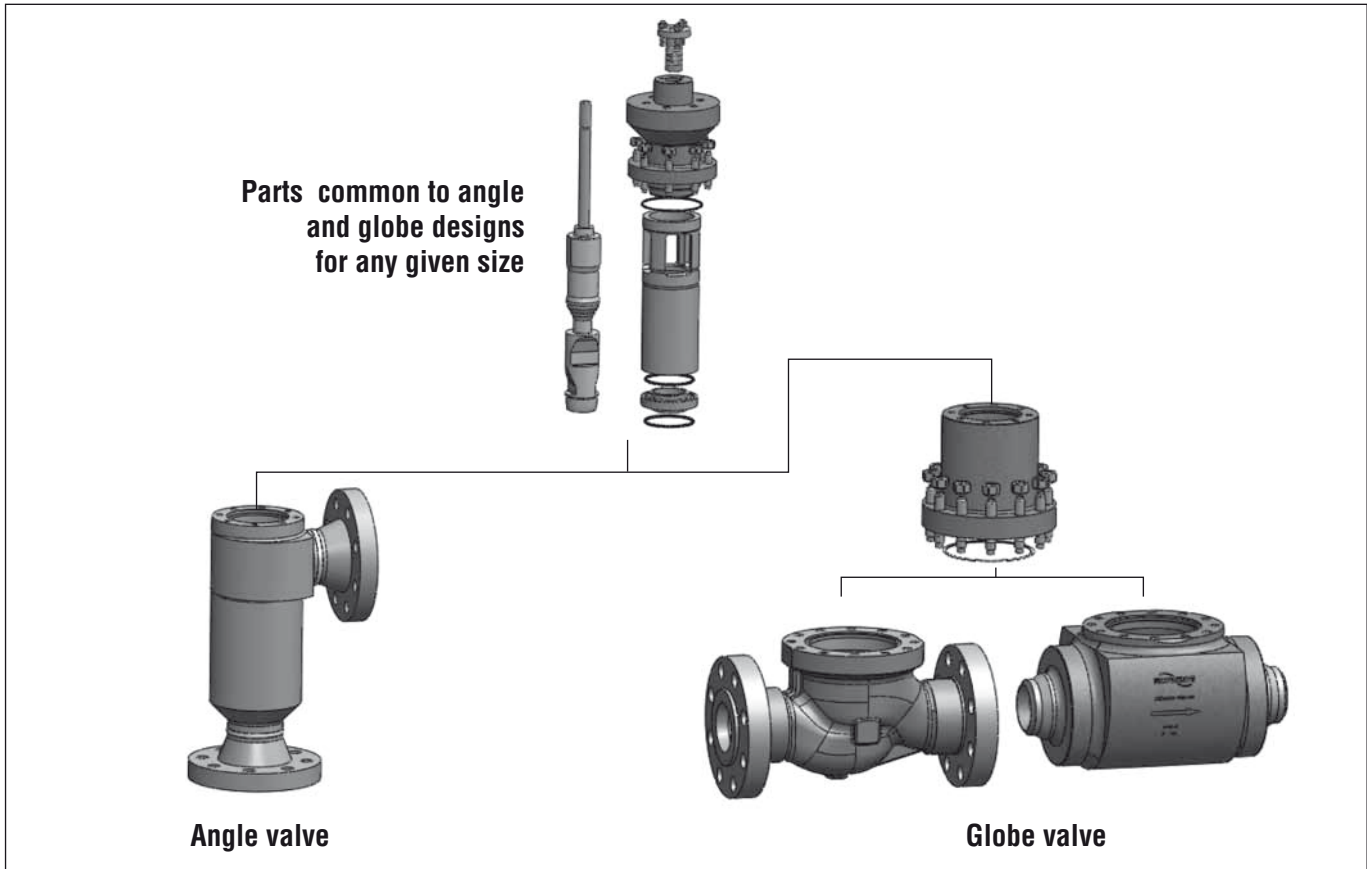

The internal parts and the bonnet are identical for both angle and globe valve designs for any given valve size.

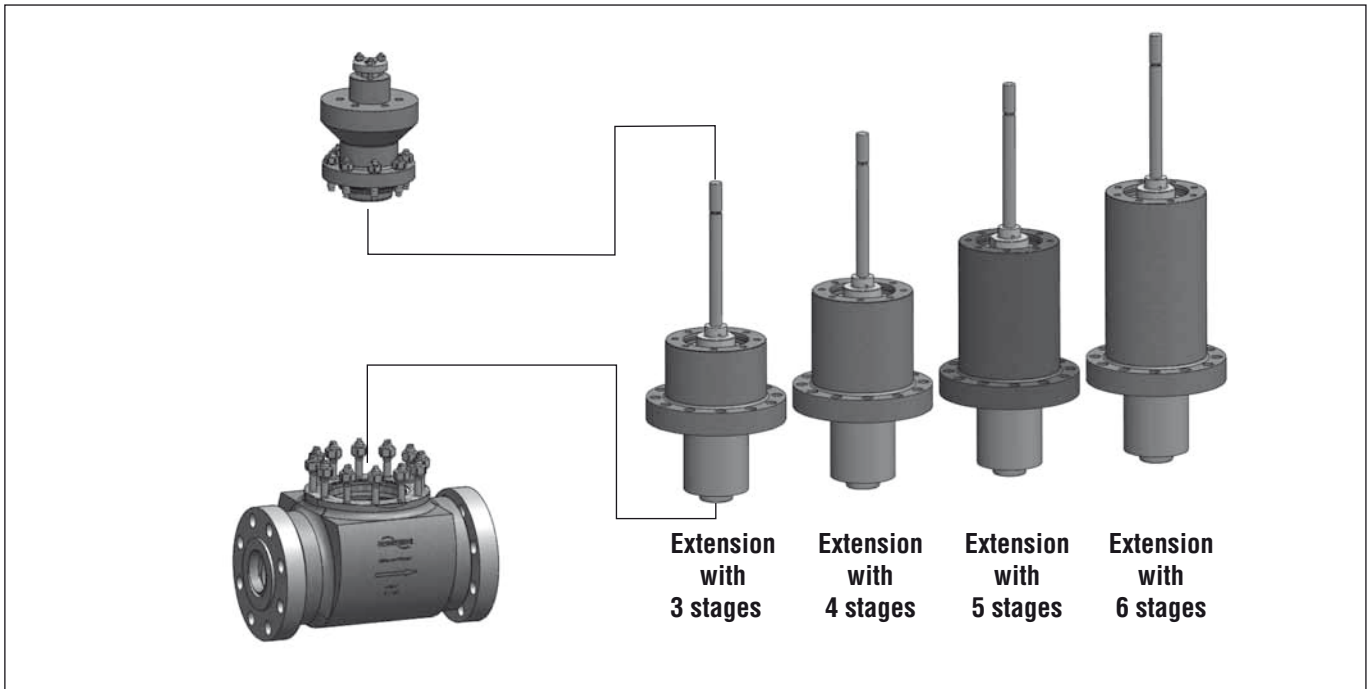

Globe valve: for a given valve size an extension with any number of stages can be chosen using the same body and bonnet. (field upgrade possible by changing the extension, plug and liner)

**Principle of cavitation elimination**

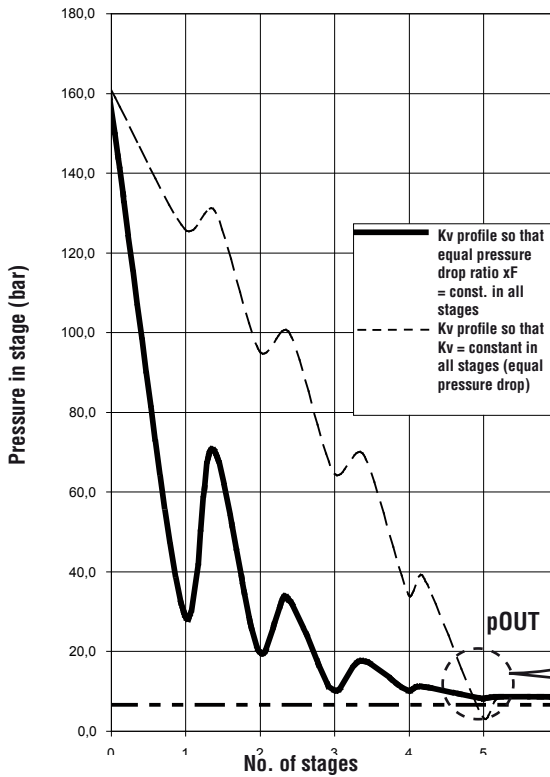

Pressure profile through 5 stage valve in different profiles

The phenomenon of cavitation occurs when the pressure of the medium drops, for a short time, below the vapor pressure ( $P_v$ ). Behind the vena contracta the pressure recovers and cavitation occurs. To achieve zero cavitation the Multi-Z trim divides the pressure into several parts (3-6, depending on the applications). Every stage is machined to keep the Sigma (respective  $xP$ ) constant. The diagram illustrates the difference between constant  $\Delta P$  (solid line) and constant Sigma (dotted line). The advantage is the last stage where a small  $\Delta p$  does not reach  $P_v$ . Physically the Multi-Z uses the high potential in the first stages to have only a low  $\Delta P$  in the last stage.

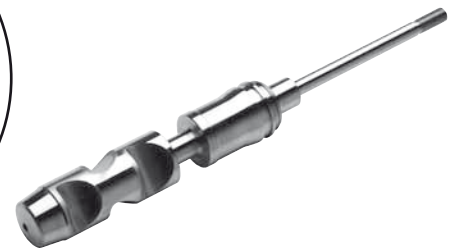
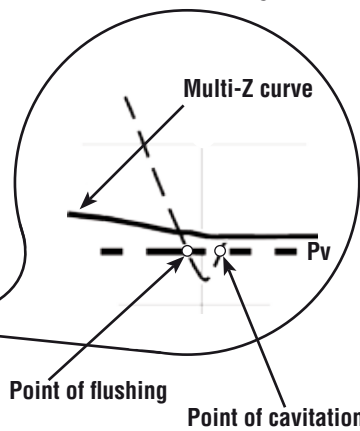

The trim is available with custom flow, modified linear and modified equal percentage characteristics. The first 10% of the stroke provides seat protection to achieve better control resolution. The Multi-Z utilizes longer stroke length through complete product range providing more  $C_v$ .

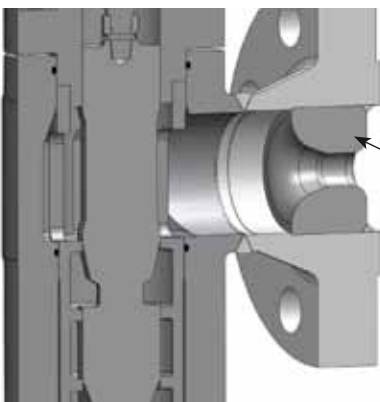
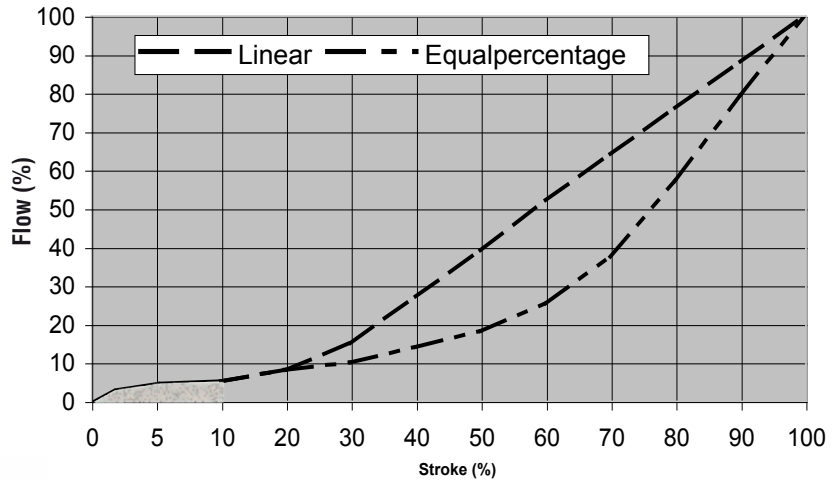

**Venturi outlet**

In flashing applications or where  $P_v$  is greater than  $P_2$  the valve can be fitted with a venturi nozzle integrated into the outlet port. This will ensure that the pressure within the valve is always above the vapor pressure.

## Industry Applications

<b>Refinery</b>	Charge Pump Recirculation
	Amine Letdown
	Hot High Pressure Letdown
	Cold High Pressure Letdown
<b>Oilfield</b>	Produced Water Injection
	HP Injection Control
<b>Power</b>	Boiler Feedwater Recirculation
	Boiler Feedwater Startup
	Sootblower
<b>All Plants</b>	High Pressure Drop Application
	Water Letdown

## Packing options

Low emission sealing systems according to ISO 15848 and TA-Luft

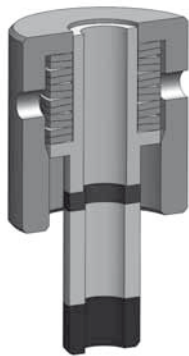

Compact design  
up to PN 63 / CL 600



Mixed packing



V-Ring packing live loaded



Standard packing  
PTFE or Graphite

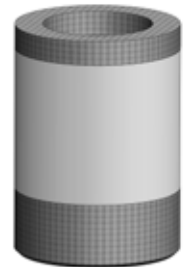

Packing cartridge  
SAS preformed graphite pack-  
ing with metal inlays and ISO  
certification 15848 B

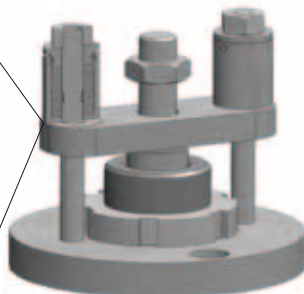
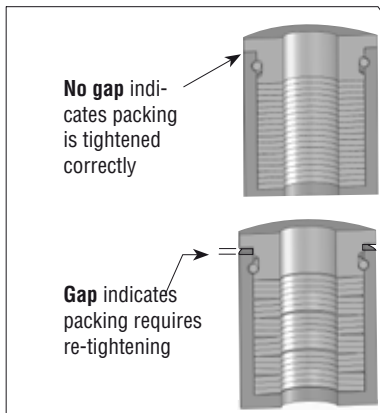

## Bellows seal

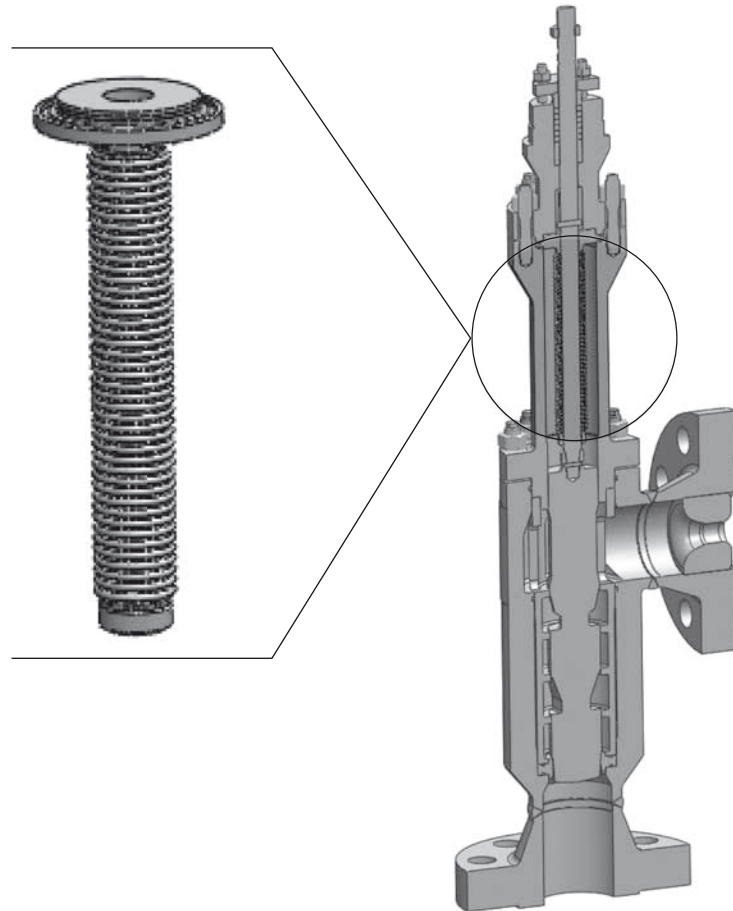

To protect personnel and the environment toxic or aggressive mediums must be processed in a closed system. Valtek bellows seals fulfil the requirements of the German “TA-Luft”

Valtek design includes a rugged hydroformed bellows seal with the backup packing seal located well above the bellows. For maximum protection, bellows are provided with up to five walls with wall thickness from 0.1 to 0.15 mm (for greater wall flexibility). A leak detection port is standard.

Valtek offers a variety of bellows seals, providing the best cycle life in the business. Depending on the pressure and temperature, bellow designs can exceed 1 million cycles. To ensure the integrity of the bellows seal, each new valve or bellows seal spare part is tested using a stringent helium leak test.

Instead of a welded bellows design, only hydroformed bellows seals are used because of their strength and ability to withstand pressure, especially in high pressures. Because minimal welding is required for hydroformed bellows, they are available in a wider variety of materials, such as 300 series stainless steels, Hastelloy® C 276, Nickel, Monel®, Titanium, Inconel® and PTFE.

**Sealing options**

According to medium and application the Multi-Z offers various sealing options.

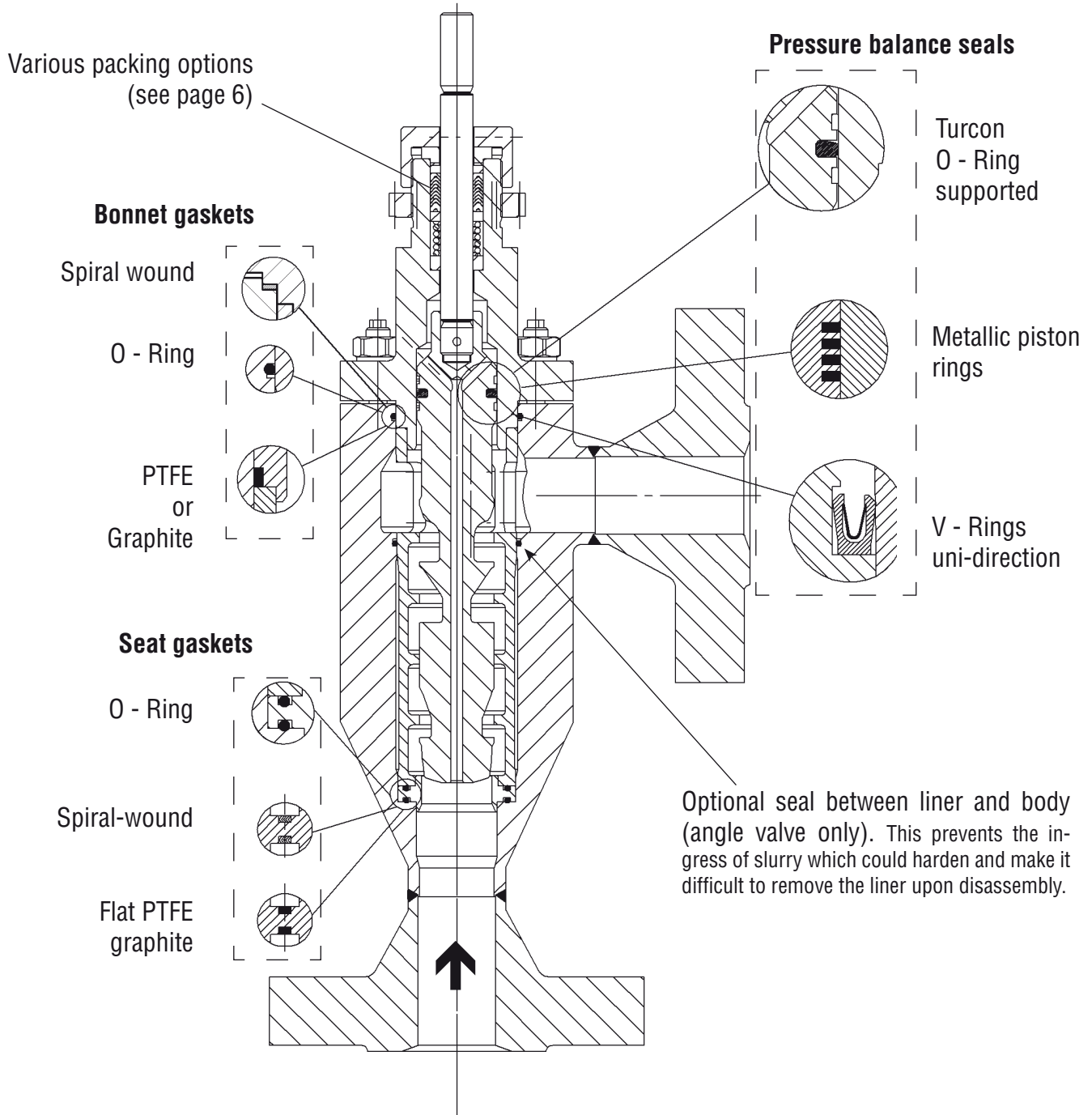

**Soft seat**

The soft seat parts move away from the Vena Contracta before flow commences to reduce erosion. In the shutoff position there is double contact from soft seat (primary) and metal to metal (secondary).

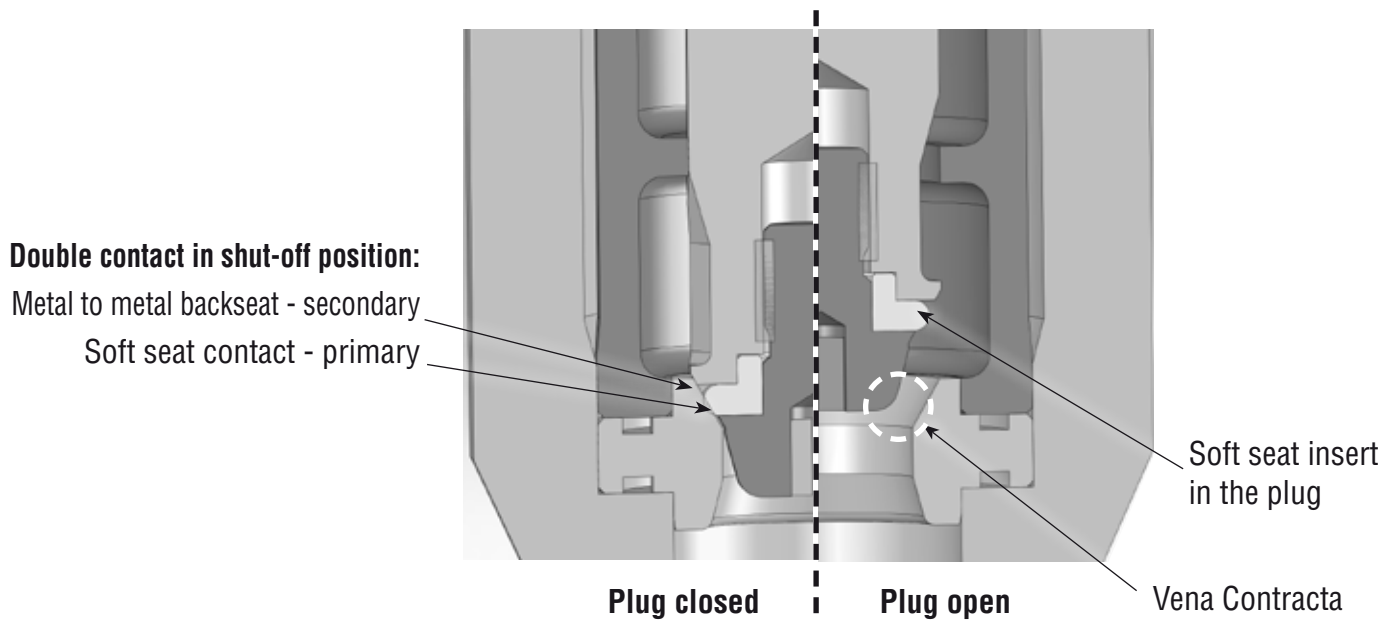

## Flow capacity and solid size

The flow capacity is governed to the number of stages. More stages allow a higher pressure drop without cavitation. The AXIAL FLOW MULTI STAGE design provides multiple stages to maximize performance in a given service condition. The calculation is based on the Sigma resp. xFz the indicators for incipient cavitation.

A very important factor is the maximum solid size. Big solids require larger gaps where best AntiCavitation requires smaller gaps. For this reason the Multi-Z can be supplied with 2 different trims:

Trim A. Optimized for medium with high delta P and solids.

Trim B. Optimized for solid size and reduced erosion. A higher Sigma (= reduced xFz) per stage gives longer lifetime and larger gaps for solids.

Metric Units		DN	25	40/50	65	80	100	150	200
Trim Type		Stroke [mm]	10	15	20	25	40	60	60
3 stages <sup>1)</sup>	Trim A xFz total = 0.957 σ total = 1.045 <sup>2)</sup>	Cvs range <sup>4)</sup>	1.1 - 2.7	2.9 - 9.0	4.9 - 18.4	5.9 - 25.1	9.2 - 47.2	15.0 - 90.4	21.1 - 150.7
		Cvs (controlable)	0.11	0.29	0.49	0.59	0.92	1.50	2.11
		max. solid size <sup>3)</sup>	0.05	0.08	0.13	0.15	0.22	0.30	0.35
	Trim B xFz total = 0.875 σ total = 1.143 <sup>2)</sup>	Cvs range <sup>4)</sup>	1.1 - 3.5	2.9 - 11.8	4.9 - 24.1	5.9 - 32.8	9.2 - 61.7	15.0 - 118.1	21.1 - 196.8
		Cvs (controlable)	0.11	0.29	0.49	0.59	0.92	1.50	2.11
		max. solid size <sup>3)</sup>	0.07	0.12	0.19	0.21	0.31	0.42	0.50
4 stages <sup>1)</sup>	Trim A xFz total = 0.985 σ total = 1.015 <sup>2)</sup>	Cvs range <sup>4)</sup>	0.9 - 1.6	2.4 - 5.3	4.0 - 10.5	4.8 - 14.6	7.5 - 27.2	12.2 - 52.2	17.2 - 87.1
		Cvs (controlable)	0.09	0.24	0.40	0.48	0.75	1.22	1.72
		max. solid size <sup>3)</sup>	0.03	0.05	0.08	0.09	0.13	0.17	0.21
	Trim B xFz total = 0.938 σ total = 1.067 <sup>2)</sup>	Cvs range <sup>4)</sup>	0.9 - 2.4	2.4 - 8.1	4.0 - 15.7	4.8 - 22.4	7.5 - 42.1	12.2 - 80.7	17.2 - 134.4
		Cvs (controlable)	0.09	0.24	0.40	0.48	0.75	1.22	1.72
		max. solid size <sup>3)</sup>	0.05	0.08	0.13	0.15	0.22	0.30	0.35
5 stages <sup>1)</sup>	Trim A xFz total = 0.995 σ total = 1.005 <sup>2)</sup>	Cvs range <sup>4)</sup>	0.8 - 0.9	2.0 - 3.1	3.4 - 6.2	4.2 - 8.6	6.5 - 15.8	10.6 - 30.7	14.9 - 51.2
		Cvs (controlable)	0.08	0.20	0.34	0.42	0.65	1.06	1.49
		max. solid size <sup>3)</sup>	0.02	0.03	0.05	0.05	0.07	0.10	0.12
	Trim B xFz total = 0.969 σ total = 1.032 <sup>2)</sup>	Cvs range <sup>4)</sup>	0.8 - 1.7	2.0 - 5.6	3.4 - 11.4	4.2 - 15.6	6.5 - 29.3	10.6 - 56.1	14.9 - 93.5
		Cvs (controlable)	0.08	0.20	0.34	0.42	0.65	1.06	1.49
		max. solid size <sup>3)</sup>	0.03	0.06	0.10	0.11	0.16	0.21	0.25
6 stages <sup>1)</sup>	Trim A xFz total = 0.998 σ total = 1.002 <sup>2)</sup>	Cvs range <sup>4)</sup>	0.5 - 0.5	1.8 - 1.8	3.1 - 3.7	3.7 - 5.0	5.8 - 9.3	9.5 - 18.5	13.3 - 30.9
		Cvs (controlable)	0.07	0.18	0.31	0.37	0.58	0.95	1.33
		max. solid size <sup>3)</sup>	0.01	0.02	0.03	0.03	0.04	0.06	0.07
	Trim B xFz total = 0.984 σ total = 1.016 <sup>2)</sup>	Cvs range <sup>4)</sup>	0.7 - 1.2	1.8 - 3.9	3.1 - 7.9	3.7 - 10.9	5.8 - 20.6	9.5 - 39.4	13.3 - 65.6
		Cvs (controlable)	0.07	0.18	0.31	0.37	0.58	0.95	1.33
		max. solid size <sup>3)</sup>	0.02	0.04	0.07	0.08	0.11	0.15	0.18

1) Variable stages (without fix nozzle as last stage)

2) For total pressure drop ratio up to xF total or down to σ total: without cavitation

3) At 100% stroke

4) Maximum Cv is associated to σ total. Please consult Flowserve for higher needed Cv.

**Imperial Units**

Size		1"	1.5"/2"	2.5"	3"	4"	6"	8"	
Trim Type	Stroke [inch]	0.39	0.59	0.79	0.98	1.57	2.36	2.36	
3 stages <sup>1)</sup>	Trim A xFz total = 0.957 σ total = 1.045 <sup>2)</sup>	Cv range <sup>4)</sup>	1.1 - 2.7	2.9 - 9.0	4.9 - 18.4	5.9 - 25.1	9.2 - 47.2	15.0 - 90.4	21.1 - 150.7
		Cv (controlable)	0.11	0.29	0.49	0.59	0.92	1.50	2.11
		max. solid size <sup>3)</sup>	0.05	0.08	0.13	0.15	0.22	0.30	0.35
	Trim B xFz total = 0.875 σ total = 1.143 <sup>2)</sup>	Cv range <sup>4)</sup>	1.1 - 3.5	2.9 - 11.8	4.9 - 24.1	5.9 - 32.8	9.2 - 61.7	15.0 - 118.1	21.1 - 196.8
		Cv (controlable)	0.11	0.29	0.49	0.59	0.92	1.50	2.11
		max. solid size <sup>3)</sup>	0.07	0.12	0.19	0.21	0.31	0.42	0.50
4 stages <sup>1)</sup>	Trim A xFz total = 0.985 σ total = 1.015 <sup>2)</sup>	Cv range <sup>4)</sup>	0.9 - 1.6	2.4 - 5.3	4.0 - 10.5	4.8 - 14.6	7.5 - 27.2	12.2 - 52.2	17.2 - 87.1
		Cv (controlable)	0.09	0.24	0.40	0.48	0.75	1.22	1.72
		max. solid size <sup>3)</sup>	0.03	0.05	0.08	0.09	0.13	0.17	0.21
	Trim B xFz total = 0.938 σ total = 1.067 <sup>2)</sup>	Cv range <sup>4)</sup>	0.9 - 2.4	2.4 - 8.1	4.0 - 15.7	4.8 - 22.4	7.5 - 42.1	12.2 - 80.7	17.2 - 134.4
		Cv (controlable)	0.09	0.24	0.40	0.48	0.75	1.22	1.72
		max. solid size <sup>3)</sup>	0.05	0.08	0.13	0.15	0.22	0.30	0.35
5 stages <sup>1)</sup>	Trim A xFz total = 0.995 σ total = 1.005 <sup>2)</sup>	Cv range <sup>4)</sup>	0.8 - 0.9	2.0 - 3.1	3.4 - 6.2	4.2 - 8.6	6.5 - 15.8	10.6 - 30.7	14.9 - 51.2
		Cv (controlable)	0.08	0.20	0.34	0.42	0.65	1.06	1.49
		max. solid size <sup>3)</sup>	0.02	0.03	0.05	0.05	0.07	0.10	0.12
	Trim B xFz total = 0.969 σ total = 1.032 <sup>2)</sup>	Cv range <sup>4)</sup>	0.8 - 1.7	2.0 - 5.6	3.4 - 11.4	4.2 - 15.6	6.5 - 29.3	10.6 - 56.1	14.9 - 93.5
		Cv (controlable)	0.08	0.20	0.34	0.42	0.65	1.06	1.49
		max. solid size <sup>3)</sup>	0.03	0.06	0.10	0.11	0.16	0.21	0.25
6 stages <sup>1)</sup>	Trim A xFz total = 0.998 σ total = 1.002 <sup>2)</sup>	Cv range <sup>4)</sup>	0.5 - 0.5	1.8 - 1.8	3.1 - 3.7	3.7 - 5.0	5.8 - 9.3	9.5 - 18.5	13.3 - 30.9
		Cv (controlable)	0.07	0.18	0.31	0.37	0.58	0.95	1.33
		max. solid size <sup>3)</sup>	0.01	0.02	0.03	0.03	0.04	0.06	0.07
	Trim B xFz total = 0.984 σ total = 1.016 <sup>2)</sup>	Cv range <sup>4)</sup>	0.7 - 1.2	1.8 - 3.9	3.1 - 7.9	3.7 - 10.9	5.8 - 20.6	9.5 - 39.4	13.3 - 65.6
		Cv (controlable)	0.07	0.18	0.31	0.37	0.58	0.95	1.33
		max. solid size <sup>3)</sup>	0.02	0.04	0.07	0.08	0.11	0.15	0.18

1) Variable stages (without fix nozzle as last stage)

2) For total pressure drop ratio up to xF total or down to σ total: without cavitation

3) At 100% stroke

4) Maximum Cv is associated to σ total. Please consult Flowserve for higher needed Cv.

**Construction and Materials**

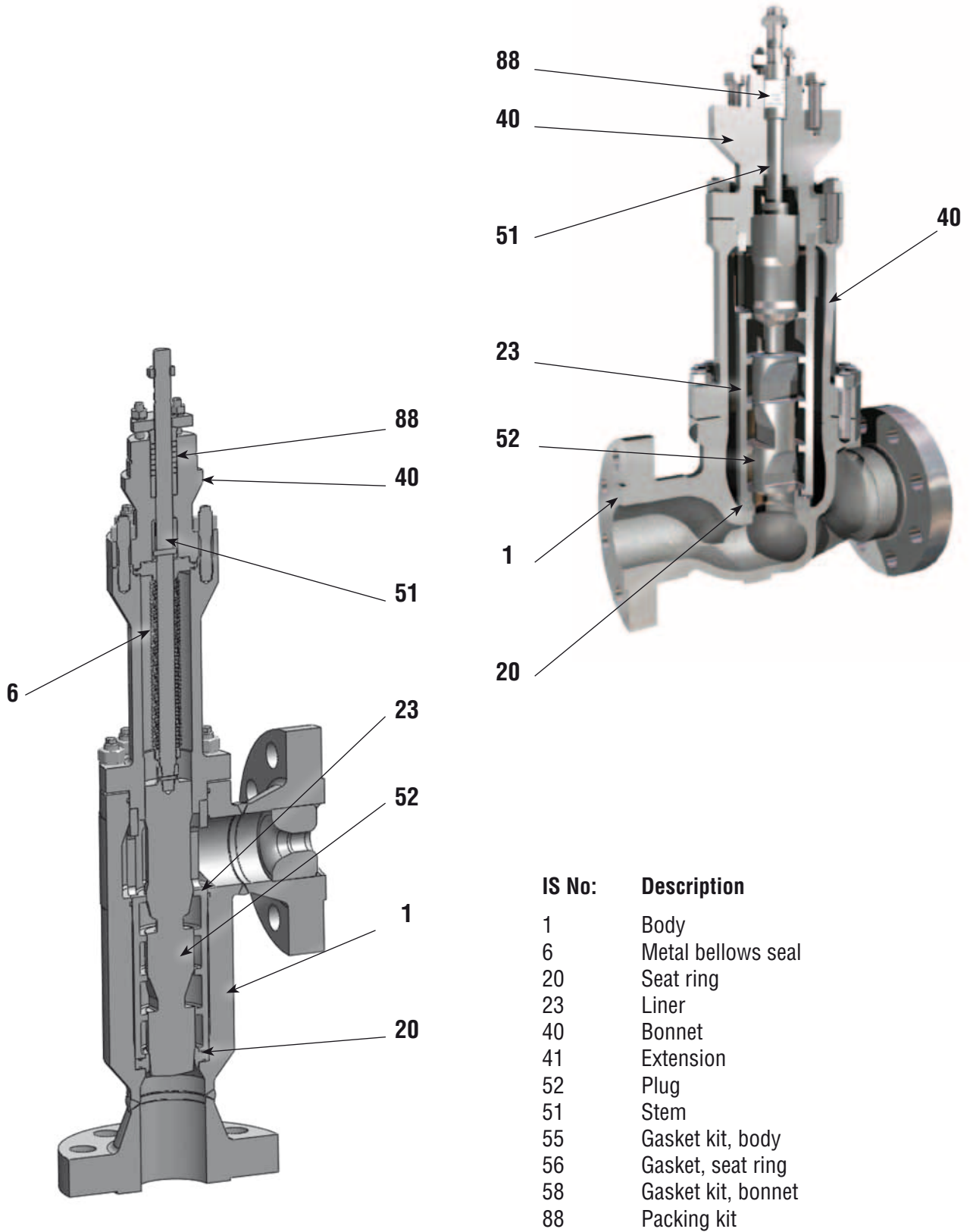

## Materials of Construction

### Body (1)

Materials	ANSI			DIN		
	Stainless Steel	Carbon Steel	Chrom Moly Steel	SS	CS	Chrom Moly Steel
Cast	CF8M	WCB	WC9	1.4408	1.0619	1.7357
Forging / Bar stock	316	A105	F22	1.4571	1.0432	1.7335

### Bonnet (40) and Extension (41)

Materials	ANSI			DIN		
	Stainless Steel	Carbon Steel	Chrom Moly Steel	Stainless Steel	Carbon Steel	Chrom Moly Steel
	316	A105	F22	1.4571	1.0432	1.7335

### Trim parts

Materials	Plug (50)	Seat (52)	Liner (22)	Stem (51)	Soft seat
		440B hardened Duplex <sup>1)</sup> Hastelloy <sup>1)</sup> Inconel <sup>1)</sup> Specials		1.4571 1.4548.4 Nitronic Hastelloy Specials	PTFE PCTFE Specials

<sup>1)</sup> Surface kolsterisiet

### Packing (88)

	Material	Maximum Pressure	Certificates
Standard	PTFE	250 bar (3626 psi)	
	Graphite	250 bar (3626 psi)	
Live loaded	Sureguard HP LL	160 bar (2320 psi)	ISO 15848 Class B
	Sureguard HP 325	325 bar (4713 psi)	TA-Luft
	ISO C V-Ring	100 bar (1450 psi)	ISO 15848 Class C

### Metal Bellows Seal (6)

	Material	Maximum Pressure
	1.4571	100 bar (1450 psi)
	Hastelloy C276	325 bar (4713 psi)

## Dimensions

### Angle Valves, ANSI

Forged Body, End Connections RF and RTJ, Valtek Standard

Valve Size (Inch)	CL 300						CL 600					
	A	B3	B4	B5	B6	C	A	B3	B4	B5	B6	C
1	CF	CF	CF	CF	CF	3.94	3.74	5.91	6.69	7.48	8.27	3.94
1.5	CF	CF	CF	CF	CF	54	5.51	8.66	9.84	112	12.20	54
2	CF	CF	CF	CF	CF	54	5.71	8.86	104	11.22	12.40	54
2.5	CF	CF	CF	CF	CF	5.71	6.10	9.84	11.22	12.80	14.17	5.71
3	CF	CF	CF	CF	CF	6.69	6.89	10.83	12.60	14.37	16.14	6.69
4	CF	CF	CF	CF	CF	8.27	8.86	15.55	18.31	216	242	8.27

Valve Size (mm)	CL 300						CL 600					
	A	B3	B4	B5	B6	C	A	B3	B4	B5	B6	C
1	CF	CF	CF	CF	CF	100	95	150	170	190	210	100
1.5	CF	CF	CF	CF	CF	128	140	220	250	280	310	128
2	CF	CF	CF	CF	CF	128	145	225	255	285	315	128
2.5	CF	CF	CF	CF	CF	145	155	250	285	325	360	145
3	CF	CF	CF	CF	CF	170	175	275	320	365	410	170
4	CF	CF	CF	CF	CF	210	225	395	465	535	610	210

### Globe Valves, DIN - DIN EN 558

Forged Body, End Connections EN 1092-1 B1 / B2

Valve Size (Inch)	PN40					PN63/100				
	A	C3	C4	C5	C6	A	C3	C4	C5	C6
25	6.30	---	8.15	8.15	9.02	9.06	---	8.15	8.15	9.02
40	7.87	9.17	10.35	11.54	12.72	10.24	9.17	10.35	11.54	12.72
50	9.06	9.17	10.35	11.54	12.72	11.81	9.17	10.35	11.54	12.72
65	11.42	CF	CF	CF	CF	13.39	CF	CF	CF	CF
80	12.20	12.99	14.76	16.54	18.31	14.96	12.99	14.76	16.54	18.31
100	13.78	17.17	20.00	22.83	25.67	16.93	17.17	20.00	22.83	25.67

Valve Size (mm)	PN40					PN63/100				
	A	C3	C4	C5	C6	A	C3	C4	C5	C6
25	160.0	---	207	207	229	230	---	207	207	229
40	200.0	233	263	293	323	260	233	263	293	323
50	230.0	233	263	293	323	300	233	263	293	323
65	290.0	CF	CF	CF	CF	340	CF	CF	CF	CF
80	310.0	330	375	420	465	380	330	375	420	465
100	350.0	436	508	580	652	430	436	508	580	652

All dimensions C are designed for Valtek piston actuators.

The use of other actuator may change the dimension Cx.

B3, C3 = valve with 3 stages

B4, C4 = valve with 4 stages

CL 900						CL 1500					
A	B3	B4	B5	B6	C	A	B3	B4	B5	B6	C
4.72	6.69	7.48	8.27	96	3.94	4.72	6.69	7.48	8.27	96	3.94
5.91	96	10.24	11.42	12.60	54	5.91	96	10.24	11.42	12.60	54
6.69	9.84	112	12.20	13.39	54	6.69	9.84	112	12.20	13.39	54
79	112	12.20	13.78	15.35	5.71	79	112	12.20	13.78	15.35	5.71
7.68	11.42	13.19	14.96	16.73	6.69	8.27	121	13.78	15.55	17.32	6.69
9.25	15.94	18.70	21.46	24.41	8.27	9.84	16.34	199	21.85	24.80	8.27

CL 900						CL 1500					
A	B3	B4	B5	B6	C	A	B3	B4	B5	B6	C
120	170	190	210	230	100	120	170	190	210	230	100
150	230	260	290	320	128	150	230	260	290	320	128
170	250	280	310	340	128	170	250	280	310	340	128
180	280	310	350	390	145	180	280	310	350	390	145
195	290	335	380	425	170	210	305	350	395	440	170
235	405	475	545	620	210	250	415	485	555	630	210

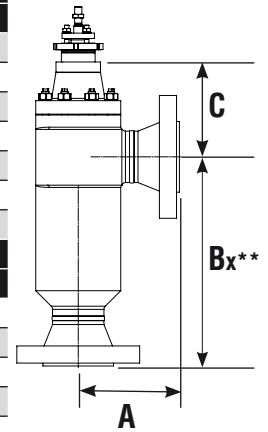

\*\* x = number of stages

PN160					PN250				
A	C3	C4	C5	C6	A	C3	C4	C5	C6
9.06	---	8.15	8.15	9.02	10.24	---	8.15	8.15	9.02
10.24	9.17	10.35	11.54	12.72	11.81	9.17	10.35	11.54	12.72
11.81	9.17	10.35	11.54	12.72	13.78	9.17	10.35	11.54	12.72
13.39	CF	CF	CF	CF	15.75	CF	CF	CF	CF
14.96	12.99	14.76	16.54	18.31	17.72	12.99	14.76	16.54	18.31
16.93	17.17	20.00	22.83	25.67	20.47	17.17	20.00	22.83	25.67

PN160					PN250				
A	C3	C4	C5	C6	A	C3	C4	C5	C6
230	---	207	207	229	260	---	207	207	229
260	233	263	293	323	300	233	263	293	323
300	233	263	293	323	350	233	263	293	323
340	CF	CF	CF	CF	400	CF	CF	CF	CF
380	330	375	420	465	450	330	375	420	465
430	436	508	580	652	520	436	508	580	652

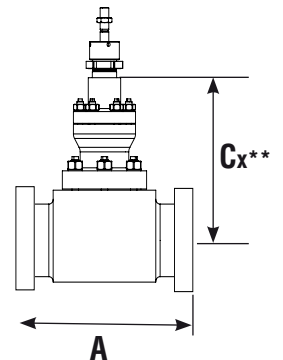

\*\* x = number of stages

## Dimensions

### Globe Valves, ANSI - ANSI / ISA 75.08.01 (CL 300 - CL 600) - ANSI / ISA 75.08.06 (CL 900 - CL 1500) Forged Body, End Connections RF

Valve Size (Inch)	CL 300					CL 600				
	A	C3	C4	C5	C6	A	C3	C4	C5	C6
1	7.76	---	8.15 *	8.15	9.02	8.27	---	8.15 *	8.15	9.02
1.5	9.25	9.17	10.35	11.54	12.72	9.88	9.17	10.35	11.54	12.72
2	10.51	9.17	10.35	11.54	12.72	11.26	9.17	10.35	11.54	12.72
2.5	11.50	0.00	0.00	0.00	0.00	12.24	0.00	0.00	0.00	0.00
3	12.52	12.99	14.76	16.54	18.31	13.27	12.99	14.76	16.54	18.31
4	14.49	17.17	20.00	22.83	25.67	15.51	17.17	20.00	22.83	25.67

Valve Size (mm)	CL 300					CL 600				
	A	C3	C4	C5	C6	A	C3	C4	C5	C6
1	197.0	---	207 *	207	229	210	---	207 *	207	229
1.5	235.0	233	263	293	323	251	233	263	293	323
2	267.0	233	263	293	323	286	233	263	293	323
2.5	292.0	CF	CF	CF	CF	311	CF	CF	CF	CF
3	318.0	330	375	420	465	337	330	375	420	465
4	368.0	436	508	580	652	394	436	508	580	652

### Globe Valves, ANSI - ANSI / ISA 75.08.01 (CL 300 - CL 600) - ANSI / ISA 75.08.06 (CL 900 - CL 1500) Forged Body, End Connections RTJ

Valve Size (Inch)	CL 300					CL 600				
	A	C3	C4	C5	C6	A	C3	C4	C5	C6
1	7.76	---	8.15	8.15	9.02	8.27	---	8.15	8.15	9.02
1.5	9.25	9.17	10.35	11.54	12.72	9.88	9.17	10.35	11.54	12.72
2	10.63	9.17	10.35	11.54	12.72	11.38	9.17	10.35	11.54	12.72
2.5	11.61	0.00	0.00	0.00	0.00	12.36	0.00	0.00	0.00	0.00
3	12.64	12.99	14.76	16.54	18.31	13.39	12.99	14.76	16.54	18.31
4	14.61	17.17	20.00	22.83	25.67	15.63	17.17	20.00	22.83	25.67

Valve Size (mm)	CL 300					CL 600				
	A	C3	C4	C5	C6	A	C3	C4	C5	C6
1	197.0	---	207	207	229	210	---	207	207	229
1.5	235.0	233	263	293	323	251	233	263	293	323
2	270.0	233	263	293	323	289	233	263	293	323
2.5	295.0	CF	CF	CF	CF	314	CF	CF	CF	CF
3	321.0	330	375	420	465	340	330	375	420	465
4	371.0	436	508	580	652	397	436	508	580	652

All dimensions C are designed for Valtek piston actuators.  
The use of other actuator may change the dimension Cx.

B3, C3 = valve with 3 stages

B4, C4 = valve with 4 stages

CL 900					CL 1500				
A	C3	C4	C5	C6	A	C3	C4	C5	C6
11.50	---	8.15 *	8.15	9.02	11.50	---	8.15 *	8.15	9.02
13.11	9.17	10.35	11.54	12.72	13.11	9.17	10.35	11.54	12.72
14.76	9.17	10.35	11.54	12.72	14.76	9.17	10.35	11.54	12.72
16.14	0.00	0.00	0.00	0.00	16.14	0.00	0.00	0.00	0.00
17.36	12.99	14.76	16.54	18.31	18.11	12.99	14.76	16.54	18.31
20.12	17.17	20.00	22.83	25.67	20.87	17.17	20.00	22.83	25.67

CL 900					CL 1500				
A	C3	C4	C5	C6	A	C3	C4	C5	C6
292	---	207 *	207	229	292	---	207 *	207	229
333	233	263	293	323	333	233	263	293	323
375	233	263	293	323	375	233	263	293	323
410	CF	CF	CF	CF	410	CF	CF	CF	CF
441	330	375	420	465	460	330	375	420	465
511	436	508	580	652	530	436	508	580	652

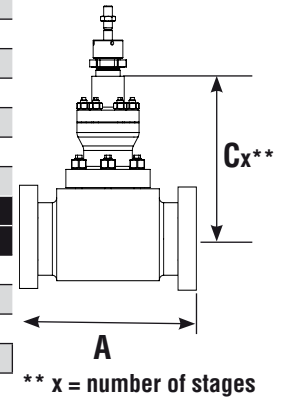

CL 900					CL 150				
A	C3	C4	C5	C6	A	C3	C4	C5	C6
11.50	---	8.15	8.15	9.02	11.50	---	8.15	8.15	9.02
13.11	9.17	10.35	11.54	12.72	13.11	9.17	10.35	11.54	12.72
14.88	9.17	10.35	11.54	12.72	14.88	9.17	10.35	11.54	12.72
16.26	0.00	0.00	0.00	0.00	16.26	0.00	0.00	0.00	0.00
17.36	12.99	14.76	16.54	18.31	18.23	12.99	14.76	16.54	18.31
20.24	17.17	20.00	22.83	25.67	20.98	17.17	20.00	22.83	25.67

  

CL 900					CL 1500				
A	C3	C4	C5	C6	A	C3	C4	C5	C6
292	---	207	207	229	292	---	207	207	229
333	233	263	293	323	333	233	263	293	323
378	233	263	293	323	378	233	263	293	323
413	CF	CF	CF	CF	413	CF	CF	CF	CF
441	330	375	420	465	463	330	375	420	465
514	436	508	580	652	533	436	508	580	652

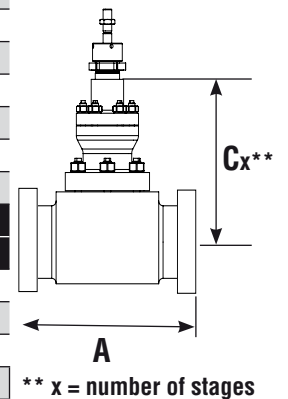

## Dimensions

Globe Valves, ANSI - ANSI / ISA 75.08.01 (CL 600) - ANSI / ISA 75.08.06 (CL 900 - CL 1500)  
Cast Body, End Connections RF

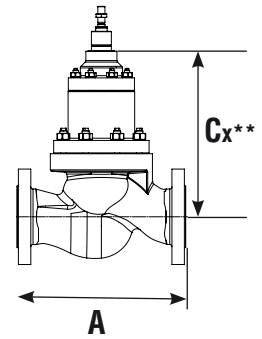

\*\* x = number of stages

Valve Size (Inch)	CL 600					CL 900					CL 1500				
	A	C3	C4	C5	C6	A	C3	C4	C5	C6	A	C3	C4	C5	C6
1	8.27	---	8.15 *	8.15	9.02	11.50	---	8.15 *	8.15	9.02	11.50	---	8.15 *	8.15	9.02
1.5	9.88	9.17	10.35	11.54	12.72	13.11	9.17	10.35	11.54	12.72	13.11	9.17	10.35	11.54	12.72
2	11.26	9.17	10.35	11.54	12.72	14.76	9.17	10.35	11.54	12.72	14.76	9.17	10.35	11.54	12.72
3	13.27	12.68	14.45	16.22	17.99	17.36	12.68	14.45	16.22	17.99	18.11	12.68	14.45	16.22	17.99
4	15.51	17.44	20.28	23.11	25.94	20.12	17.44	20.28	23.11	25.94	20.87	17.44	20.28	23.11	25.94

Valve Size (mm)	CL 600					CL 900					CL 1500				
	A	C3	C4	C5	C6	A	C3	C4	C5	C6	A	C3	C4	C5	C6
1	210	---	207 *	207	229	292	---	207 *	207	229	292	---	207 *	207	229
1.5	251	233	263	293	323	333	233	263	293	323	333	233	263	293	323
2	286	233	263	293	323	375	233	263	293	323	375	233	263	293	323
3	337	322	367	412	457	441	322	367	412	457	460	322	367	412	457
4	394	443	515	587	659	511	443	515	587	659	530	443	515	587	659

Globe Valves, ANSI - ANSI / ISA 75.08.01 (CL 600) - ANSI / ISA 75.08.06 (CL 900 - CL 1500)  
Cast Body, End Connections RTJ

Valve Size (Inch)	CL 600					CL 900					CL 1500				
	A	C3	C4	C5	C6	A	C3	C4	C5	C6	A	C3	C4	C5	C6
1	8.27	---	8.15 *	8.15	9.02	11.50	---	8.15 *	8.15	9.02	11.50	---	8.15 *	8.15	9.02
1.5	9.88	9.17	10.35	11.54	12.72	13.11	9.17	10.35	11.54	12.72	13.11	9.17	10.35	11.54	12.72
2	11.38	9.17	10.35	11.54	12.72	14.88	9.17	10.35	11.54	12.72	14.88	9.17	10.35	11.54	12.72
3	13.39	12.68	14.45	16.22	17.99	17.36	12.68	14.45	16.22	17.99	18.23	12.68	14.45	16.22	17.99
4	15.63	17.44	20.28	23.11	25.94	20.24	17.44	20.28	23.11	25.94	20.98	17.44	20.28	23.11	25.94

Valve Size (mm)	CL 600					CL 900					CL 1500				
	A	C3	C4	C5	C6	A	C3	C4	C5	C6	A	C3	C4	C5	C6
1	210	---	207 *	207	229	292	---	207 *	207	229	292	---	207 *	207	229
1.5	251	233	263	293	323	333	233	263	293	323	333	233	263	293	323
2	289	233	263	293	323	378	233	263	293	323	378	233	263	293	323
3	340	322	367	412	457	441	322	367	412	457	463	322	367	412	457
4	397	443	515	587	659	514	443	515	587	659	533	443	515	587	659

All dimensions C are designed for Valtek piston actuators.  
The use of other actuator may change the dimension Cx.

\* 5 stage ; 1st stage On/Off

## Dimensions

Globe Valves, ANSI - ANSI / ISA 75.08.05 (CL 600 - CL 1500)  
 Cast Body, End Connections Butt Weld

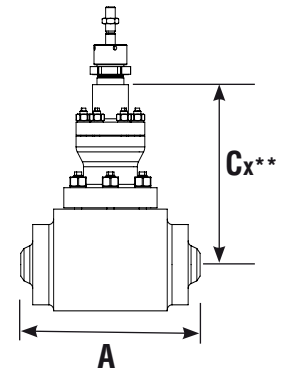

\*\* x = number of stages

Valve Size (Inch)	CL 600					CL 900					CL 1500				
	A	C3	C4	C5	C6	A	C3	C4	C5	C6	A	C3	C4	C5	C6
1	7.75	---	8.15 *	8.15	9.02	7.75	---	8.15 *	8.15	9.02	7.75	---	8.15 *	8.15	9.02
1.5	9.25	9.17	10.35	11.54	12.72	9.25	9.17	10.35	11.54	12.72	9.25	9.17	10.35	11.54	12.72
2	14.75	9.17	10.35	11.54	12.72	14.75	9.17	10.35	11.54	12.72	14.75	9.17	10.35	11.54	12.72
3	17.38	12.68	14.45	16.22	17.99	17.38	12.68	14.45	16.22	17.99	18.12	12.68	14.45	16.22	17.99
4	20.12	17.44	20.28	23.11	25.94	20.12	17.44	20.28	23.11	25.94	20.87	17.44	20.28	23.11	25.94

Valve Size (mm)	CL 600					CL 900					CL 1500				
	A	C3	C4	C5	C6	A	C3	C4	C5	C6	A	C3	C4	C5	C6
1	197	---	207 *	207	229	197	---	207 *	207	229	197	---	207 *	207	229
1.5	235	233	263	293	323	235	233	263	293	323	235	233	263	293	323
2	375	233	263	293	323	375	233	263	293	323	375	233	263	293	323
3	441	322	367	412	457	441	322	367	412	457	498	322	367	412	457
4	511	443	515	587	659	511	443	515	587	659	575	443	515	587	659



**Flowserve Corporation**  
Flow Control  
1350 N. Mt. Springs Parkway  
Springville, UT 84663  
USA  
Phone: +1 801 489 8611  
Fax: +1 801 489 3719

**Flowserve (Austria) GmbH**  
Control Valves - Villach Operation  
Kasernengasse 6  
9500 Villach  
Austria  
Phone: +43 (0)4242 41181 0  
Fax: +43 (0)4242 41181 50

**Flowserve India Controls Pvt. Ltd**  
Plot # 4, 1A, E.P.I.P, Whitefield  
Bangalore Karnataka  
India 560 066  
Phone: +91 80 401 46 200  
Fax: +91 80 284 10 286

Your contact:



All data subject to change without notice  
©07.2009 Flowserve Corporation. Flowserve and Valtek are registered trademarks of Flowserve Corporation